

YBF9207GR

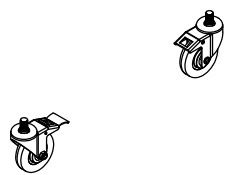
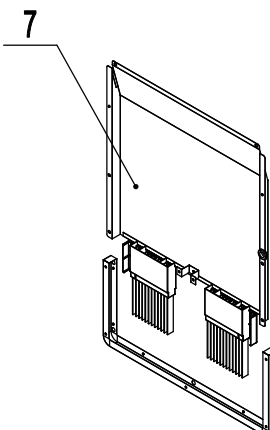
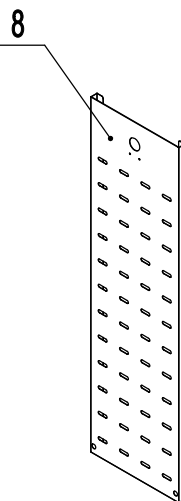
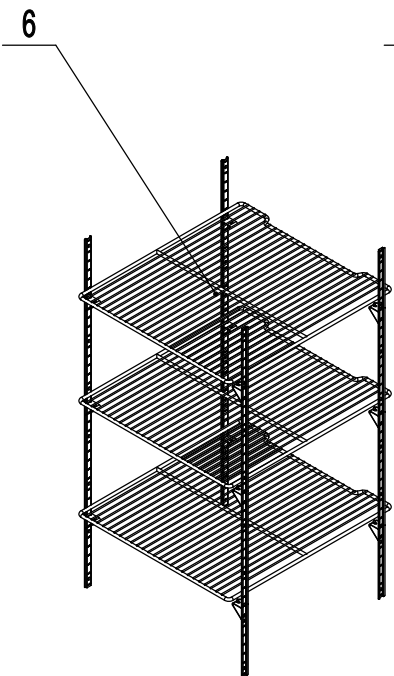
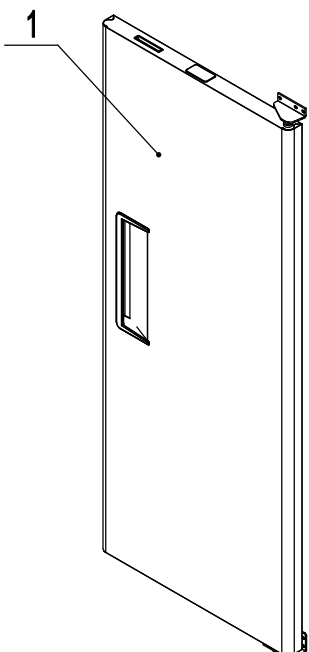
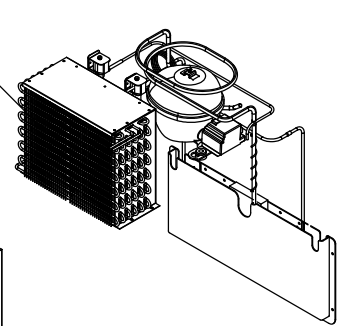
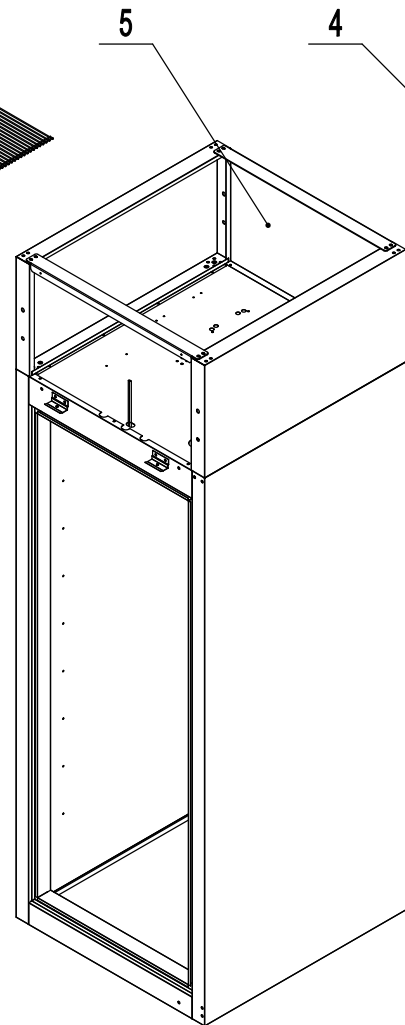
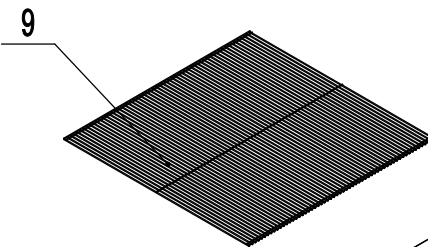
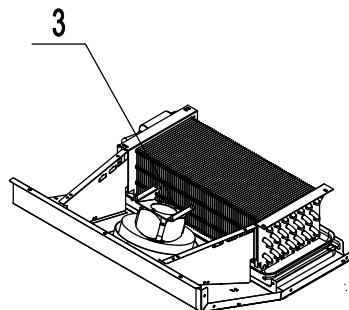
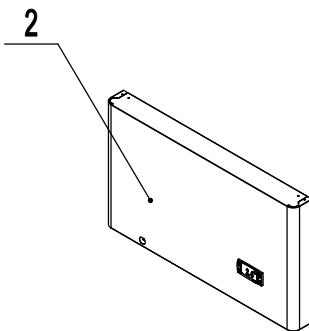

10

11

11	B0604413	4" Castor Without Brake	4吋重磅万向轮 (脚轮)	2	
10	B0604421	4" Castor With Brake	4吋带刹车重磅万向轮[刹定向]	2	
9	W0402691	top of wire cage	箱体顶部保护网	Q235a	1
8	92001026-430	Back wind deflector	后背导风板	SUS430	1

7	92040108	Water evaporation assembly	水蒸发组件		1	
6	92060106	Shelf Assembly	食品架组件		1	
5	92070105	Cabinet Assembly	箱体组件		1	
4	92070104	Comp&Cond Assembly	冷凝组件		1	
3	92070103	Evaporator Assembly	蒸发组件		1	
2	92070102	Top Panel Assembly	前罩组件		1	
1	92060101	Solid Door Assembly	门体组件		1	
	Material code	English Name	Chinese Name	MATERIAL	QUANTITY	Remark

92060101

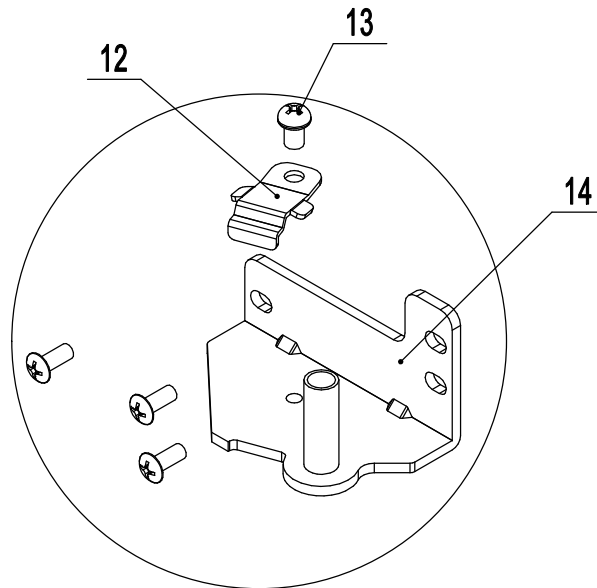
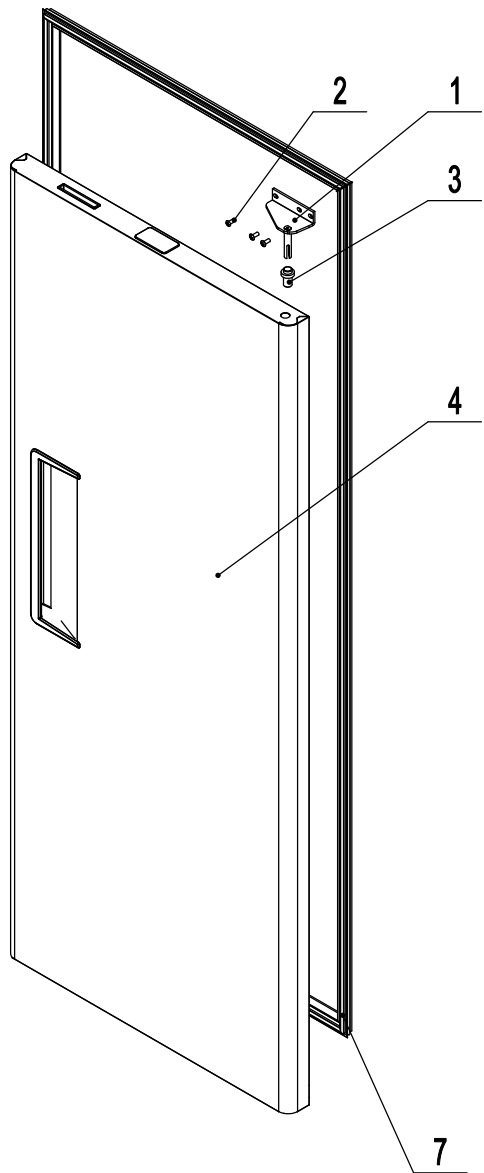

局部放大图A

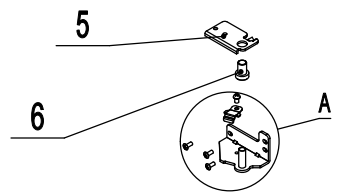

14	W0604037	Right-Bottom Hinge	右下铰链	SUS304	1	
13	B0507015	SS Screw M6x8	M6x8不锈钢螺丝		1	
12	W0604038	Door Brake-Bottom	门自锁装置-下	SUS304	1	
11	W0604944	Door Spring Bar	门体发条		1	
7	W0404904	Door Gasket	门封条		1	
6	W0409843	Door Shaft Sleeve-Bottom	门体轴套	PA66	1	
5	W0604030	Door Brake -Right	门自锁装置-右	SUS304	1	
4	92060224	Right Door	右门体		1	
3	W0409842	Door Shaft Sleeve-Top	门体轴套	PA66	1	
2	B0502207	SS Screw M5x12	M5x12不锈钢螺丝		6	
1	W0604033	Right-Top Hinge	右上铰链	SUS304	1	
序号	Material code	English Name	Chinese Name	MATERIAL	QUANTITY	Remark

92070102

A

B

C

D

1

2

3

4

5

6

1

5

2

6

3

4

6	W0409161	Gate Magnetic Switch	门磁开关组件		1	
5	80021404	Fastener For Top Panel	上罩板上加固件	SUS430	2	
4	W0302303	Controller Cover	防水后盖		1	
3	W0302166-CF0G4D10	Digital Controller	三点电子温控器 (蒸汽门磁开关程序)		1	220V
2	W0604007	Lock	冰箱锁		1	
1	92001411-430	FRONT TOP PANEL-TOP	整体前罩板	SUS430	1	
序号	Material code	English Name	Chinese Name	MATERIAL	QUANTITY	Remark

1

2

3

4

5

6

92070103

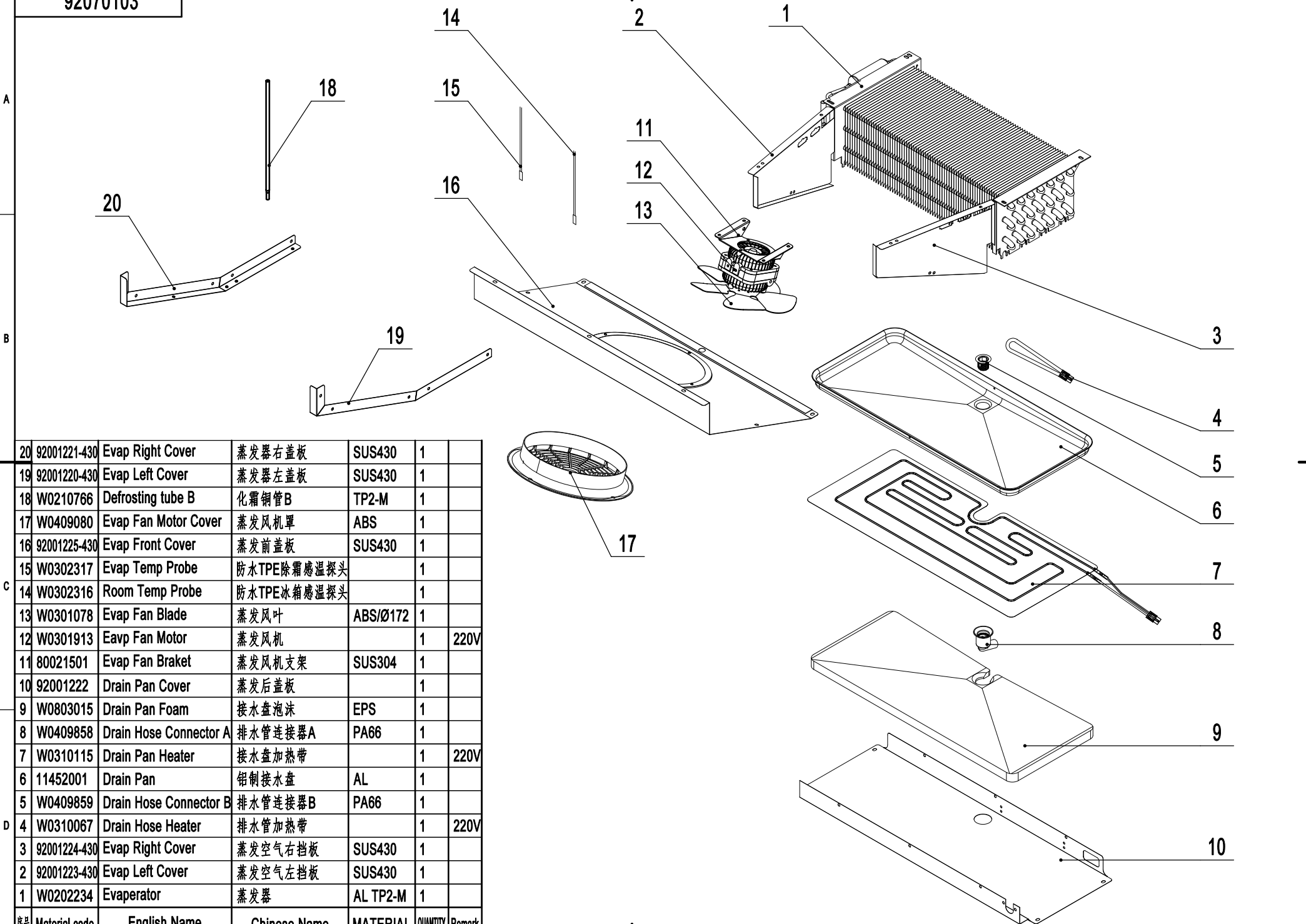

20	92001221-430	Evap Right Cover	蒸发器右盖板	SUS430	1	
19	92001220-430	Evap Left Cover	蒸发器左盖板	SUS430	1	
18	W0210766	Defrosting tube B	化霜铜管B	TP2-M	1	
17	W0409080	Evap Fan Motor Cover	蒸发风机罩	ABS	1	
16	92001225-430	Evap Front Cover	蒸发前盖板	SUS430	1	
15	W0302317	Evap Temp Probe	防水TPE除霜感温探头		1	
14	W0302316	Room Temp Probe	防水TPE冰箱感温探头		1	
13	W0301078	Evap Fan Blade	蒸发风叶	ABS/Ø172	1	
12	W0301913	Evap Fan Motor	蒸发风机		1	220V
11	80021501	Evap Fan Bracket	蒸发风机支架	SUS304	1	
10	92001222	Drain Pan Cover	蒸发后盖板		1	
9	W0803015	Drain Pan Foam	接水盘泡沫	EPS	1	
8	W0409858	Drain Hose Connector A	排水管连接器A	PA66	1	
7	W0310115	Drain Pan Heater	接水盘加热带		1	220V
6	11452001	Drain Pan	铝制接水盘	AL	1	
5	W0409859	Drain Hose Connector B	排水管连接器B	PA66	1	
4	W0310067	Drain Hose Heater	排水管加热带		1	220V
3	92001224-430	Evap Right Cover	蒸发空气右挡板	SUS430	1	
2	92001223-430	Evap Left Cover	蒸发空气左挡板	SUS430	1	
1	W0202234	Evaporator	蒸发器	AL TP2-M	1	
序号	Material code	English Name	Chinese Name	MATERIAL	QUANTITY	Remark

92070104

A

B

C

D

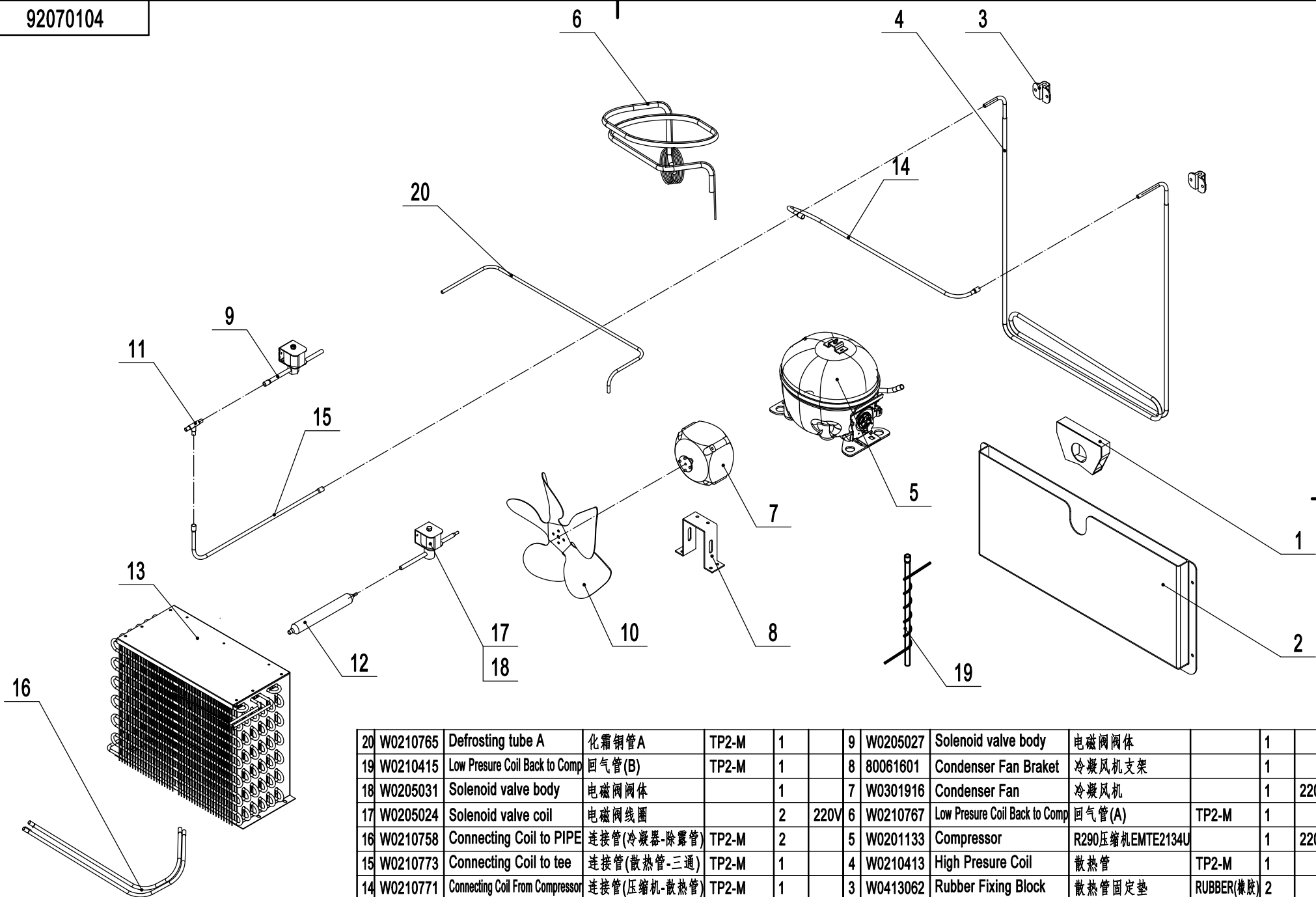

20	W0210765	Defrosting tube A	化霜铜管A	TP2-M	1		9	W0205027	Solenoid valve body	电磁阀阀体		1	
19	W0210415	Low Pressure Coil Back to Comp	回气管(B)	TP2-M	1		8	80061601	Condenser Fan Bracket	冷凝风机支架		1	
18	W0205031	Solenoid valve body	电磁阀阀体		1		7	W0301916	Condenser Fan	冷凝风机		1	220V
17	W0205024	Solenoid valve coil	电磁阀线圈		2	220V	6	W0210767	Low Pressure Coil Back to Comp	回气管(A)	TP2-M	1	
16	W0210758	Connecting Coil to PIPE	连接管(冷凝器-除霜管)	TP2-M	2		5	W0201133	Compressor	R290压缩机EMTE2134U		1	220V
15	W0210773	Connecting Coil to tee	连接管(散热管-三通)	TP2-M	1		4	W0210413	High Pressure Coil	散热管	TP2-M	1	
14	W0210771	Connecting Coil From Compressor	连接管(压缩机-散热管)	TP2-M	1		3	W0413062	Rubber Fixing Block	散热管固定垫	RUBBER(橡胶)	2	
13	W0203073	Condenser	冷凝器	GI TP2-M	1		2	W0409071	Back High Pressure Coil Pan	后背蒸发包	PP	1	
12	W0204101	Dry Filter	干燥过滤器	TP2-M	1		1	W0409078	Air pressure balance device	后背蒸发包水封	ABS	1	
11	W0208017	'T' Three way connecting pipe	T型三通	TP2-M	1								
10	W0301061	Condenser Fan Blade	冷凝风叶	AL/Ø230	1		解号	Material code	English Name	Chinese Name	MATERIAL	QUANTITY	Remark

1

2

3

4

5

6

D

92070105

A

B

C

D

A

B

C

D

1

2

3

4

5

6

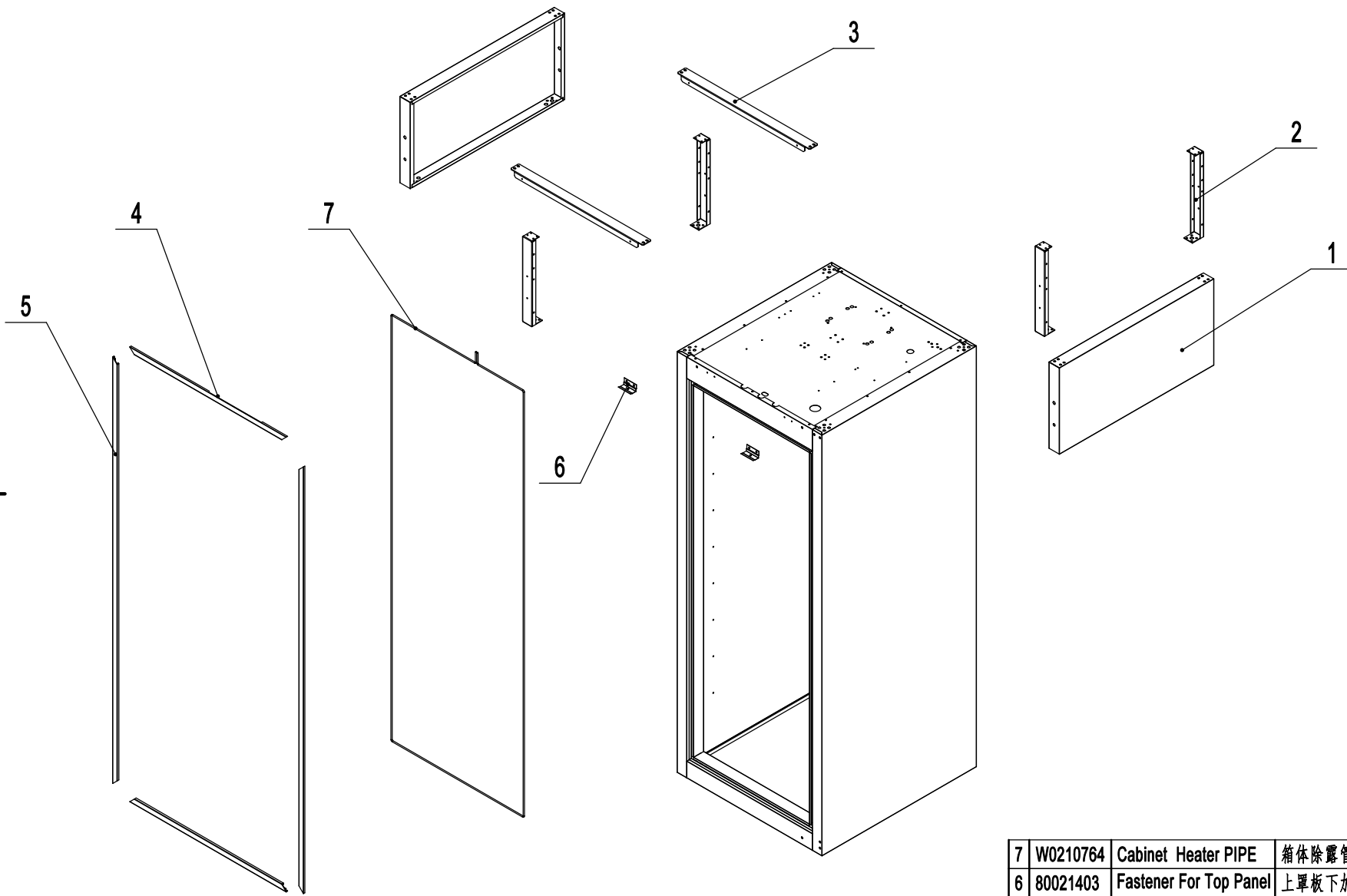

7	W0210764	Cabinet Heater PIPE	箱体除露管	GI	1	
6	80021403	Fastener For Top Panel	上單板下加固件	SUS430	2	
5	W04101039	Left-Right Frame Cover	箱体左右接口盖	PVC-H	2	
4	W04101040	Top-Bottom Frame Cover	箱体上下接口盖	PVC-H	2	
3	92001801	Top Long Fixing Rack	箱体横向固定架	GI	2	
2	11451501	Side Panel Frame	箱体支撑架	GI	4	
1	92040906	Top Side Panel	箱体上侧板	SUS430	2	
序号	Material code	English Name	Chinese Name	MATERIAL	QUANTITY	Remark

92060106

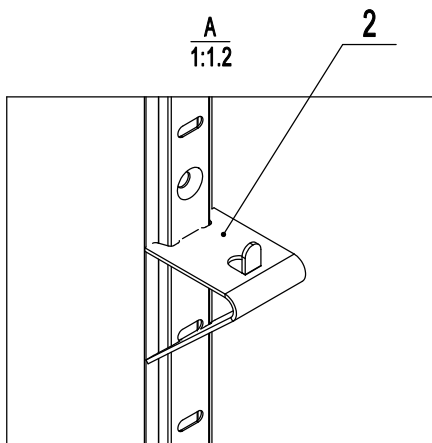
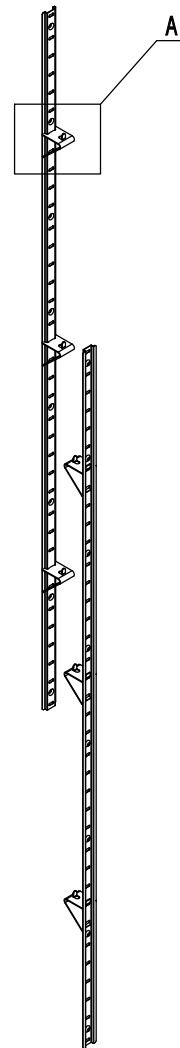
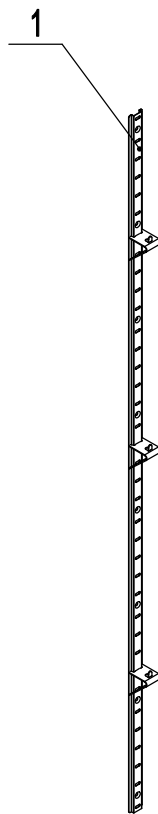
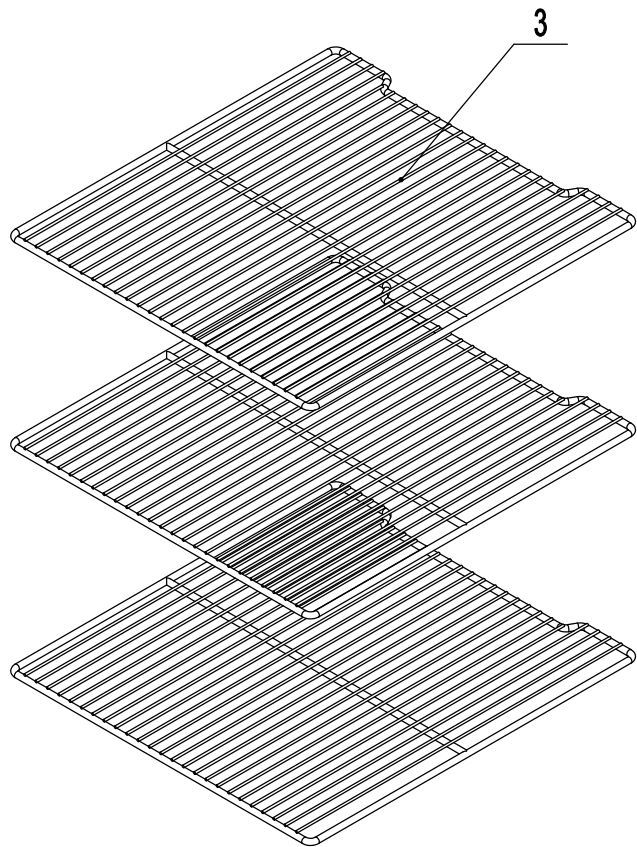

A
1:1.2

3	W0402673	Shelf	食品架		3	
2	66490313	Shelf Support Clip	食品架搁脚	SUS430	12	
1	80037410	Pilaster For Shelf	食品架隔条	SUS430	4	
序号	Material code	English Name	Chinese Name	MATERIAL	QUANTITY	Remark

92040108

A

A

B

B

C

C

D

D

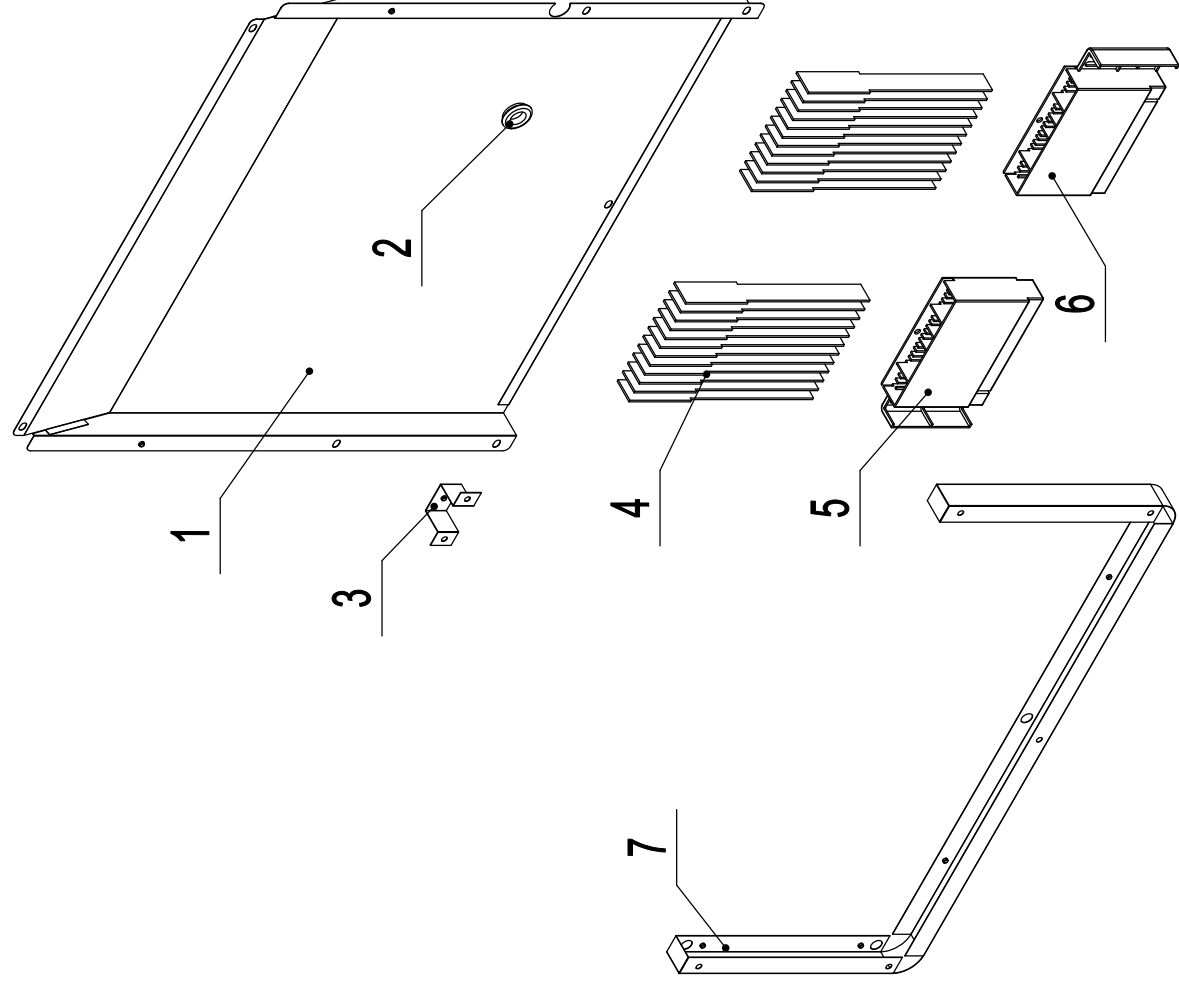

Material code	English Name	Chinese Name	MATERIAL	QUANTITY	Remark
7 92041821	Side fixing plate for Air deflector	蒸发包固定件		1	
6 W0409086	Left bracket for Absorbent paper	左吸水纸支架		1	
5 W0409087	Right bracket for Absorbent paper	右吸水纸支架		1	
4 W0499920	Absorbent paper	吸水纸		24	
3 80011814	Middle fixing plate for Air deflector	蒸发包导风板固定件		1	
2 W0413019	Rubber sleeve	橡胶套（护线圈）		1	
1 92040921	Air deflector	蒸发包导风板		1	
料号					

1

2

3

4