

# Exploded view

# SK-329 (220V/50HZ)

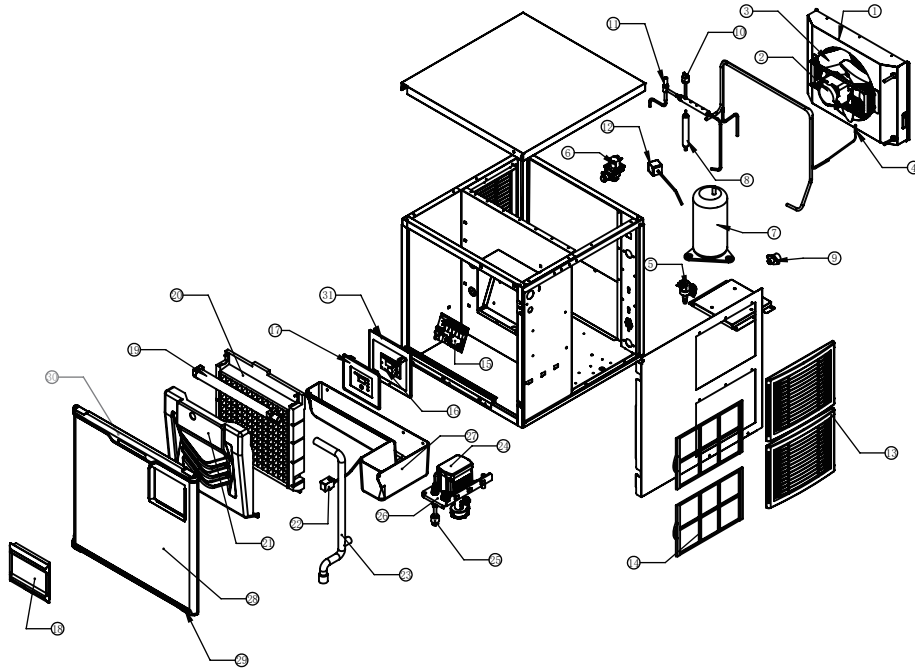

Ref	Part No.	Name	Specification
1	06.0.0050-00	Microchannel Condenser-329A	Sk-329-Sanhua Z011-Jd10
2	06.1.0051-01	Fan	M4Q045-Da01-01/A30 230Vac 50/60Hz 18W
3	06.1.0030-00	Fan Blades	Φ254 34° Aluminium
4	08.1.0025-00	Condensation Sensor	Stainless Steel Probe 1000mm
5	06.6.0037-00	Inlet Valve	4.0L/Min 220V-50/60Hz 350-2000
6	06.6.0010-00	Drain Valve	220V 50/60Hz Assembly
7	06.2.0363-00	Compressor WHP03125PSY-F3BU5N	220-240V/50Hz R290
8	06.5.0053-00	Dry Filter	Φ19*150*3.1*6.5
9	04.5.0013-00	Plastic Water Joint	Black Nylon M26 M22 M1018
10	08.1.0093-00	High Voltage Switch	Yk-2.4/1.9 2.4Mpa-1.9Mpa
11	06.4.0002-00	Defrost Valve Body	6A Inner Diameter Of Outlet Pipe 6.5
12	06.4.0043-00	Defrost Valve Coil	220~240Vac Tianhao 50/60Hz 6A 750Mm
13	04.0.0112-00	Plastic Window Filter	Injection Molding Square M1075
14	04.0.0115-00	Ventilation Window Filter	Modular Ice Machine M1035
15	08.0.0142-01	PC Board	PC-446
16	08.0.0109-04	Display Panel PD-321B	Without Voice
17	04.0.0091-00	Electrical Control Fixing Plate	Injection Molding Gray With Voice M1109
18	04.0.0086-00	Control Panel Cover-Modular Ice Machine	Injection Molding Modular Ice Machine M1025
19	04.0.0202-05	Spray Pipe	13 Columns
20	06.3.0011-01	Evaporator-350	12 Rows*13Columns Chemical Nickel Plated
21	04.0.0213-00	Skateboard-350	Abs Injection Molding White
22	08.1.0107-00	Ice Full Sensor	Harness Length 750mm
23	03.0.0008-00	Upper Water Pipe-350	Spray Pipe To Water Pump 350
24	55.0.0083-00	Water Pump-350/420	220V/50Hz
25	08.1.0065-02	Water Level Water Temperature Sensor	Hall CGT-1CB 290mm
26	04.0.0084-00	Sink Pump Fixing Plate	Injection Molding Abs White M1077 350P
27	04.0.0075-00	Sink-350	350 Injection Molding M5004
28	50.0.0132-00	Front Panel Assembly-Hinged door-350/420	
29	04.0.0289-00	Door Plastic Lower End Cap	Injection Molding ABS Black
30	04.0.0288-00	Door Plastic Upper End Cap	Injection Molding ABS Black
31	02.0.0556-00	Electrical box cover	304-0.6*200.7*202.2