

Service Manual

Microwave Oven

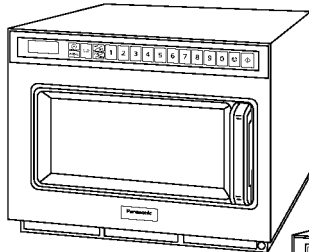

NE-1853/NE-1653

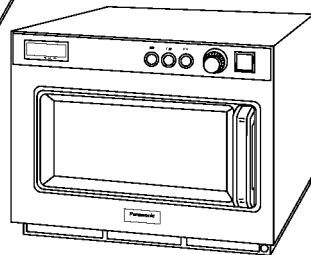

NE-1843/NE-1643

Model No. NE-1853BPQ

Destination: United Kingdom

Model No. NE-1843EUG

Destination: Continental Europe Countries

Model No. NE-1843BPQ

Destination: United Kingdom

Model No. NE-1653EUG

Destination: Continental Europe Countries

Model No. NE-1643EUG

Destination: Continental Europe Countries

⚠ WARNING

This service information is designed for experienced repair technicians only and is not designed for use by the general public. It does not contain warnings or cautions to advise non-technical individuals of potential dangers in attempting to service a product. Products powered by electricity should be serviced or repaired only by experienced professional technicians. Any attempt to service or repair the product or products dealt with in this service information by anyone else could result in serious injury or death.

IMPORTANT SAFETY NOTICE

There are special components used in this equipment which are important for safety. These parts are marked by **⚠** in the Schematic Diagrams, Circuit Board Diagrams, Exploded Views and Replacement Parts List. It is essential that these critical parts should be replaced with manufacturer's specified parts to prevent shock, fire or other hazards. Do not modify the original design without permission of manufacturer.

TABLE OF CONTENTS

	PAGE		PAGE
1 Safety Precautions	2	10 Schematic Diagram	28
2 Specifications	2	11 Exploded View and Replacement Parts List	29
3 Location of Controls and Components	3		
4 Operating Instructions	5		
5 Test Mode	18		
6 Troubleshooting Guide	20		
7 Disassembly and Assembly Instructions	22		
8 Measurements and Adjustments	26		
9 Wiring Connection Diagram	27		

1 Safety Precautions

⚠ WARNING

This service information is designed for experienced repair technicians only and is not designed for use by the general public. It does not contain warnings or cautions to advise non-technical individuals of potential dangers in attempting to service a product. Products powered by electricity should be serviced or repaired only by experienced professional technicians. Any attempt to service or repair the product or products dealt with in this service information by anyone else could result in serious injury or death.

This service manual covers products for following markets.









When troubleshooting or replacing parts, please refer to the country/AREA identifications shown below for your applicable product specification.

BPQ.....For United Kingdom EUG.....Continental Europe Countries

WARNING

This products should be serviced only by trained, qualified personnel.

2 Specifications

Models:	NE-1643	NE-1843	NE-1653	NE-1853
Power Source:	50 Hz, single phase 230V(EUG), 230-240V(BPQ)		50 Hz, single phase 230V(EUG), 230-240V(BPQ)	
Power Requirement:	11.7A 2590W	12.7A 2830W	11.7A 2590W	12.3A 2830W
*Output:	HIGH  1600 W	HIGH  1800 W	P10: 1600 W	P10: 1800 W
	MEDIUM HIGH	-----		P9: 90% P8: 80% P7: 70% P6: 60%
	MEDIUM	 800 W	 900 W	P5: 50% P4: 40%
	LOW	-----		P3: 30% P2: 25%
	DEFROST	 340 W		P1: 340 W
	OFF	-----		P0: 0%
	HEAT FROM TOP DOWN	-----		PU1: 50% PU2: 25%
	HEAT FROM BOTTOM	-----		PL1: 50% PL2: 25%
Frequency:	2,450 MHZ		2,450 MHZ	
Outside Dimensions (W×D×H)	422 mm × 508 mm × 337 mm		422 mm × 508 mm × 337 mm	
Cavity Dimensions (W×D×H)	330 mm × 310 mm × 175 mm		330 mm × 310 mm × 175 mm	
Net Weight	30 kg		30 kg	
Timer:	Maximum programmable time for heating  = 25 minutes  ,  =30 minutes		30 minutes (digital)/10 touch pads Maximum programmable time for single stage heating P1 and P0=30 minutes P10-P2, PU1-PL2=15 minutes	

*IEC Test Procedure

Specifications subject to change without notice.

3 Location of Controls and Components

3.1. Outline diagram

Outline Diagram of NE-1853/NE-1653

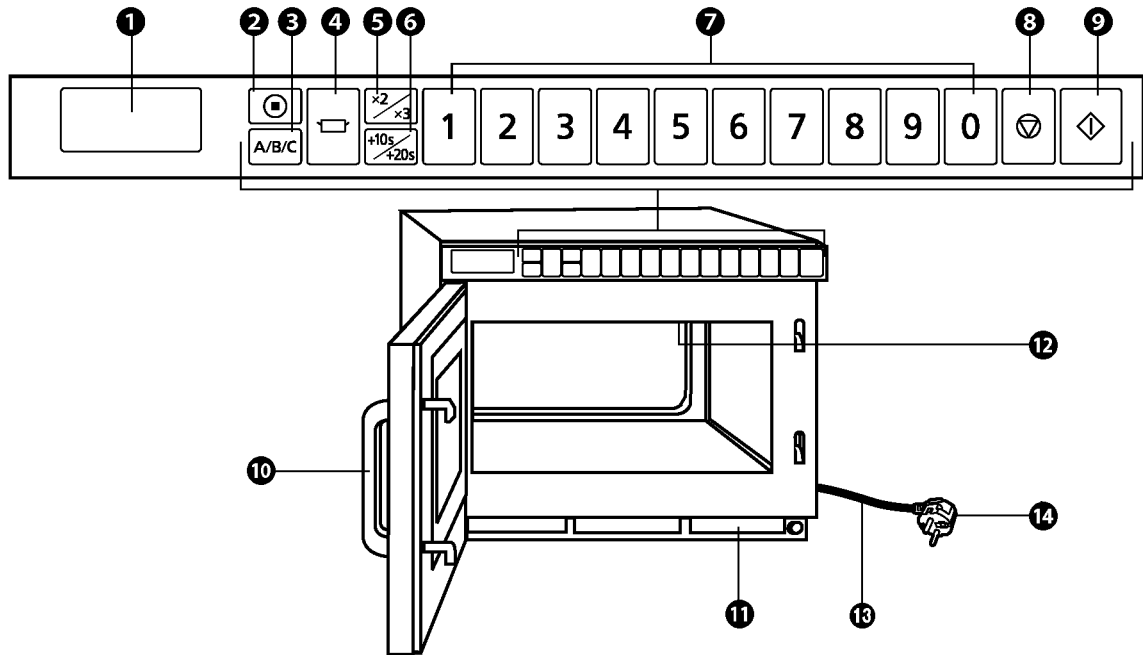

- ① Digital Display Window (see below)
- ② Prog (Program) Pad
- ③ Shift (A/B/C) Pad
- ④ Power Level Selector Pad
- ⑤ Double/Triple Quantity Pad
- ⑥ +10s/+20s Pad
- ⑦ •Number/Memory Pads
•Time Input
- ⑧ Stop/Reset Pad

- ⑨ Start Pad
- ⑩ Door Handle
- ⑪ Air Filter
- ⑫ Splatter Shield (top of inner cavity)
- ⑬ Power Cord
- ⑭ Power Plug

Caution label is attached on the outside surface.

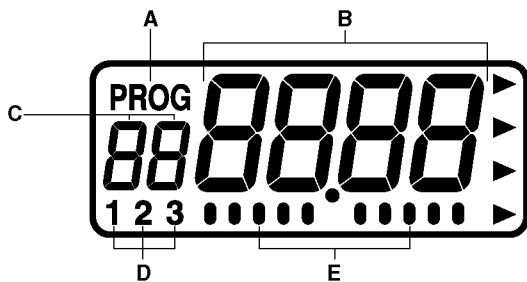

- A—Program Display
- B—Heating Time Display (“min. sec.” or “hour min.”)
- C—•Memory Pad Number Display
•Heating Stage Indicator
- D—Pattern of Buzzer Sound Setting
- E—•Calling Programmed Heating:
Stage Number Indicator
•Programmed Heating in Progress:
Operation Indicator
•Beep Tone Setting: Scale Indicator

This oven is preset at the factory for the following:

1. Manual operation
2. Number Pads preset to HIGH power at the indicated heating times for single stage heating.
A1=10 sec. A2=20 sec. A3=30 sec. A4=40 sec. A5=50 sec.
A6=1 min. A7=1 min. 15 sec. A8=1 min. 30 sec. A9=1 min. 45 sec. A0=2 min.
3. Program unlock
4. Double Quantity=1.6 times Triple Quantity=2.2 times
5. Cycle counter set to “0” on all pads.
6. Oven Lamp When the door is open = ON Blinking at the end of heating cycle = OFF
Decrease brightness during cooking = OFF
7. The default filter cleaning time is set to “500”.

If you wish to change these times, please consult the operating instructions to find how to program them.

Outline Diagram of NE-1843/NE-1643

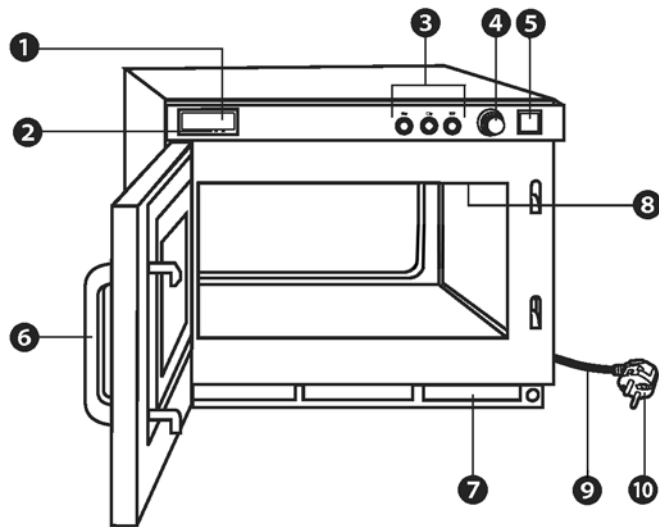

- ① Digital Display Window (see below)
- ② Power Level Indicator Display
- ③ Power Level Selector Buttons
- ④ Timer Dial
- ⑤ Start Button
- ⑥ Door Handle

- ⑦ Air Filter
- ⑧ Splatter Shield (top of inner cavity)
- ⑨ Power Cord
- ⑩ Power Plug

Caution label is attached on the outside surface.

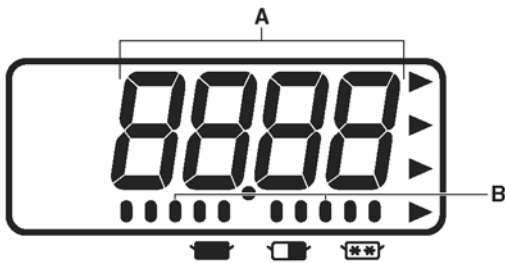

A — Heating Time Display (min. sec.)

B — Power Level Indicator

- : HIGH
- ▣ : MEDIUM
- ☐ : DEFROST

4 Operating Instructions

4.1. Operation procedure

How to Operate NE-1853/NE-1653

POWER LEVEL SELECTOR PAD

Each time the pad is pressed, the Power Level switches as the illustration below.



HIGH	P10: 1800 W* (NE-1853) P10: 1600 W* (NE-1653)	LOW	P3: 30% P2: 25%
MEDIUM HIGH	P9: 90% P8: 80% P7: 70% P6: 60%	DEFROST	P1: 340 W
		OFF	P0: 0%
MEDIUM	P5: 50% P4: 40%	HEAT FROM TOP DOWN	PU1: 50% PU2: 25%
		HEAT FROM BOTTOM UP	PL1: 50% PL2: 25%

*IEC Test Procedure

A. Manual Single Stage Heating



1. Make sure the oven is plugged into a properly earthed electrical outlet.

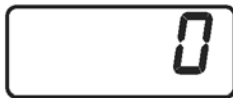

2. Open the door.
The oven lamp will turn on. "0" will appear in the Digital Display Window.
3. Put the food into a suitable container, place it in the centre of the oven and then close the door securely.
The oven lamp will turn off.
Note: While "0" appears, operation is available. 1 minute after the door is closed, "0" will disappear.



4. Select the desired Power Level by touching Power Level Selector Pad.
The selected Power Level will be displayed in the Digital Display Window and the single stage heating indicator "1" will start to blink.
[Example]: Touch Power Level Selector Pad once for HIGH power.
Note: Each time Power Level Selector Pad is touched, the Power Level switches as the above Power Level Selector illustrates.



5. Set the desired heating time by touching the appropriate Number Pads.
Note: The maximum set time for "DEFROST" and "P0" is 30 minutes, and 15 minutes for all others.
[Example]: Touch Number Pads "2", "0" and "0" for 2 minutes.



6. Touch Start Pad.
 - A. The oven lamp will turn on.
 - B. Heating will start.
 - C. During operation, the indicator appears from the left.
 - D. The heating time on digital display will count down.



7. When all time expires, the end of cycle beep tone will sound and all heating will stop.
The oven lamp will turn off. The display will blink "0000" until the door is opened.
1 minute later cooling fan will stop.

(Continued on next page.)

How to Operate NE-1853/NE-1653



8. Open the door and take the food out.
The oven lamp will turn on. The digital display will show the originally selected time and heating stage number.



9. Close the door.
The oven lamp will turn off and 1 minute later the Digital Display Window will go blank.

SPECIAL NOTE: For both single and 4 stage heating.

1. While heating, one touch on Stop/Reset Pad stops the oven. You can restart it by touching Start Pad or a second touch on Stop/Reset Pad will cancel the selected program.
2. While not in a heating cycle, one touch on Stop/Reset Pad cancels the selected program.

REPEAT FEATURE

1. You can repeat exactly the same manually selected heating time by touching only Start Pad, if you use the oven again within 1 minute.
2. After 1 minute of non-use with the door closed, the repeat feature will be cancelled.

B. Manual 2 to 5 Stage Heating



1. Follow Steps 1–5 on page 5.
2. Select the desired Power Level for the second stage heating by touching Power Level Selector Pad the appropriate number of times.
The Power Level will be displayed in the Digital Display Window and the second stage indicator "2" will start to blink.
[Example]: Touch Power Level Selector Pad 8 times for LOW power.



3. Set the desired heating time for the second stage by touching the appropriate Number Pads.
Note: The maximum set time for "DEFROST" and "P0" is 30 minutes, and 15 minutes for all others.
However, the TOTAL TIME can be set up to 25 minutes for continuous heating (1 to 5 stage heating) that excludes "DEFROST" and "P0".
[Example]: Touch Number Pads "1", "0" and "0" for 1 minute.



4. Touch Start Pad.
 - A. The total time for both stages will be displayed.
 - B. The oven lamp will turn on.
 - C. During operation, the indicator appears in order from the left.
 - D. The heating time for the first stage will count down.



5. After the first stage heating time expires, a single beep tone will sound, the second stage heating indicator "2" will start to blink, and the heating time will continue to count down.



6. When all time expires, the end of cycle beep tone will sound. All heating will stop. The oven lamp will turn off. The time display will blink "0000" until the door is opened. 1 minute later cooling fan will stop.

(Continued on next page.)

How to Operate NE-1853/NE-1653



7. Open the door and take the food out.
The oven lamp will turn on. The digital display will show the originally selected time and heating stage number.



8. Close the door.
The oven lamp will turn off and 1 minute later the Digital Display Window will go blank.

Note: For the heating cycle of the third and later stages, select Power Level once again after Step 3 on page 6 and set a heating time.

See Special Note of "Manual Single Stage Heating" on page 6.

C. Programming Memory Pads for Single Stage Heating

The oven can not be programmed until the program lock feature is deactivated.

(See page 11, J. To Activate Program Lock.)



1. Make sure the oven is plugged into a properly earthed electrical outlet.



2. Open the door and leave it open.



3. Touch Prog Pad.
"PROG" sign will start to blink in the Digital Display Window.

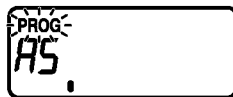

4. Touch Memory Pad you desire to program.
The pad number and the previously programmed information will appear in the Digital Display Window.
[Example]: Touch Memory Pad "5".

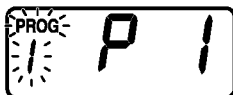

5. Select the desired Power Level by touching Power Level Selector Pad.
The selected power level will be displayed in the window and the single stage heating indicator "1" will start to blink.
[Example]: Touch Power Level Selector Pad 10 times for DEFROST power.



6. Set the desired heating time by touching the appropriate Number Pad.
Note: The maximum set time for "DEFROST" and "P0" is 30 minutes, and 15 minutes for all others.
[Example]: Touch Number Pads "1", "0" and "0" for 1 minute.

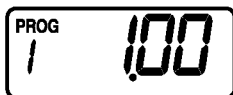

7. Touch Prog Pad again.
The "PROG" sign and the single stage heating indicator "1" will stop blinking. This means that you have completed programming the selected Memory Pad for the single stage heating.

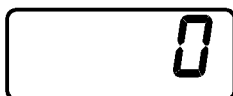

8. 3 seconds after programming is completed, "0" will appear.
9. Program the remaining Memory Pads as desired by repeating Steps 3–7 above.

Note: ●When the "PROG" Display is blinking, the program can be cancelled and/or one touch on Stop/Reset Pad erased the programmed Number/Memory Pad number.

●When you want to program B or C side, touch Shift (A/B/C) Pad before touching Program Number Pad.

How to Operate NE-1853/NE-1653

D. Programming Memory Pads for 2 to 5 Stage Heating

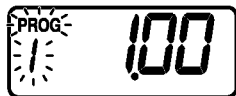

1. Complete Steps 1–6 above.



2. Select Power Level for the second stage by touching Power Level Selector Pad. The selected Power Level will be displayed in the window and the second stage heating indicator "2" will start to blink.
[Example]: Touch Power Level Selector Pad once for HIGH power.

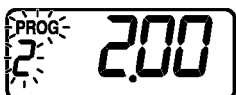

3. Set the desired heating time by touching appropriate Number Pads.
Note: The maximum set time for "DEFROST" and "P0" is 30 minutes, and 15 minutes for all others. However, the TOTAL TIME can be set up to 25 minutes, and 15 minutes for continuous heating (1 to 5 stage heating) that excludes "DEFROST" and "P0".
[Example]: Touch Number Pads "2", "0" and "0" for 2 minutes.

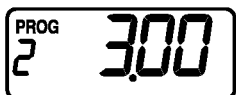

4. Touch Prog Pad again and the "PROG" sign and the second stage heating indicator "2" will stop blinking. The total time for both stages will be displayed. This means that you have completed programming the desired Memory Pad for the second stage heating.



5. 3 seconds after programming is completed, "0" will appear.
6. Program the remaining pads as desired by repeating the Steps above.
Note:
 - When you want to program B or C side, touch Shift (A/B/C) Pad before touching Program Number Pad.
 - Repeat the above procedure to set Heating for the third stage and later stages.

E. Memory Pad Heating



1. Make sure the oven is plugged into a properly earthed electrical outlet.



2. Open the door.
The oven lamp will turn on. "0" will appear in the Digital Display Window.
Note: While "0" will appear, operation is available. 1 minute after the door is closed, "0" will disappear.
3. Put the food into a suitable container, place it in the centre of the oven and then close the door securely.
The oven lamp will turn off.

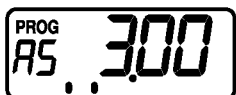

4. Touch the desired Memory Pad.
A. The currently programmed information will be indicated.
[Example]: Memory Pad "5" (Program No. A-5)
The heating program (at DEFROST power for 1 minute, at HIGH power for 2 minutes) as programmed on pages 17–18 is set.



5. Touch Start Pad.
A. The oven lamp will turn on.
B. During operation, the indicator appears in order from the left.
C. The heating time will count down.

(Continued on next page.)

How to Operate NE-1853/NE-1653



6. When all the time expires, the end of the cycle beep tone will sound. All heating will stop. The oven lamp will turn off. The time display will blink "0000" until the door is opened. 1 minute later, cooling fan will stop.



7. Open the door and take the food out.
The oven lamp will turn on.
8. Close the door.
The oven lamp will turn off and 1 minute later the Digital Display Window will go blank.

Note: To use B or C side Program, touch Shift (A/B/C) Pad before touching Program Number Pad.

F. Programming Double/Triple Quantity Pad

(The oven can not be programmed until the program lock feature is deactivated.)



1. Open the door and leave it open.
The oven lamp will turn on, and "0" will appear.

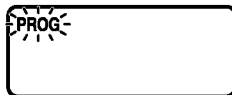

2. Touch Prog Pad.
"PROG" will blink in the Digital Display Window.

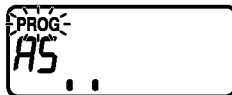

3. Touch Memory Pad for the desired program.
The pad number and the previously programmed information will appear in the display. "PROG" will start to blink.



4. Touch Double/Triple Quantity Pad once.
The previously selected magnification number will appear in the display.
[Example]: 1.6 times is **16**. (Double quantity) 2.2 times is **22**. (Triple quantity)

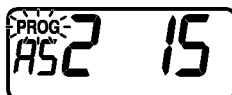

5. Set the desired magnification by touching the appropriate Number Pad.
[Example]: 1.5 times; Touch Number Pads "1" and "5".

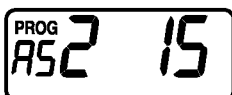

6. Touch Prog Pad again.
The "PROG" will stop blinking. This means that you have completed programming the selected Memory Pad for appropriate double quantity.

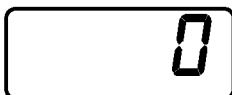

7. After 3 seconds later, "0" will appear.

Note: If you want to change appropriate time for triple quantity, you touch Double/Triple Quantity Pad twice as in Step 4 above. The magnification is preset.
Each magnification must be programmed separately for alterations.

N.B. Please test for correct times when setting the program to achieve correct temperatures.

How to Operate NE-1853/NE-1653

G. Memory Pad Heating for Double/Triple Quantity Heating

[Make sure the unit is properly programmed.]



1. Follow Steps 1–3 in “E. Memory Pad Heating”.



2. Touch Double/Triple Quantity Pad once.

Note: When you want triple quantity heating, touch Double/Triple Quantity Pad twice.

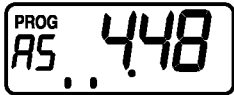

3. Touch the desired Memory Pad.

[Example]: Memory Pad 5 (Program No. A-5)



4. Touch Start Pad.

A. The oven lamp will turn on.

B. During operation, the indicator appears in order from the left.

C. The heating time will count down.

Note: If program lock is activated, the heating program starts immediately, i.e. there is no need to touch Start Pad.



5. When all time has expired, the end of the cycle beep tone will sound. All heating will stop. The oven lamp will turn off. The time display will blink “0000” until the door is opened.

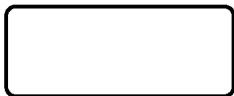

6. Open the door and remove the food. Close the door.

1 minute later the Digital Display Window will go blank.

Note: To use B or C side Program, touch Shift (A/B/C) Pad before touching Program Number Pad.

H. +10s/+20s Pad Heating



1. Make sure the oven is plugged into a properly earthed electrical outlet.

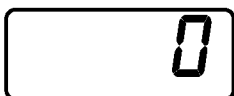

2. Open the door.

The oven lamp will turn on. “0” will appear in the Digital Display Window.

Note: While “0” will appear, operation is available. 1 minute after the door is closed, “0” will disappear.

3. Put the food into a suitable container, place it in the centre of the oven and then close the door securely.

The oven lamp will turn off.

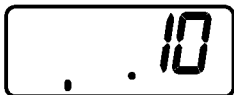

4. Touch +10s/+20s Pad once.

A. The oven lamp will turn on.

B. During operation, the indicator appears in order from the left.

C. Heating will start on HIGH power for 10 seconds.

[Example]: Touch +10s/+20s Pad once for 10 seconds.

Touch +10s/+20s Pad twice for 20 seconds.



5. When all the time expires, the end of cycle beep tone will sound. All heating will stop.

The oven lamp will turn off. The time display will blink “0000” until the door is opened.

1 minute later, cooling fan will stop.

(Continued on next page.)

How to Operate NE-1853/NE-1653



6. Open the door and take the food out.
The oven lamp will turn on.
7. Close the door.
The oven lamp will turn off and 1 minute later the Digital Display Window will go blank.

Note: While heating, one touch on Stop/Reset Pad or opening the door will cancel the heating program.

I. To Read the Cycle Counter

•To display all cooking times ever used



1. Open the door and leave it open.
The oven lamp will turn on. "0" will appear in the display.



2. While touching Start Pad, touch Number Pad "3".
All the cooking times that were ever used will appear.

•To display the cumulative number of times the oven was used

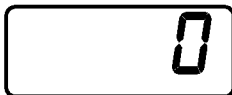

1. Open the door and leave it open.
The oven lamp will turn on. "0" will appear in the display.



2. While touching Start Pad, touch Power Level Selector Pad.
The Number of cycles that the oven has been used will appear.

Note: The last two digits are dropped from the cumulative number of times the oven was used, which is displayed in units of 100 when used over 100 times.

J. To Activate Program Lock

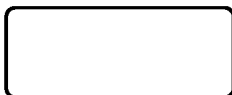

1. Make sure the oven is plugged into a properly earthed electrical outlet.

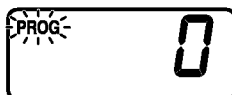

2. Open the door and leave it open.
The oven lamp will turn on. "0" will appear in the display. While touching Start Pad, touch Prog Pad until the display show "PROG", "P" and "L" (for more than 2 seconds).



3. Program Lock feature is now activated.

Note: In "Program Lock"

- a. The oven is started by touching the desired Memory Pad. There is no need to touch Start Pad.
- b. The Interrupt feature is deactivated—opening the door cancels the remaining time on the program.
- c. The oven can not be programmed or run manually until the Program Lock feature is deactivated.

K. To Deactivate Program Lock

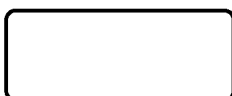

1. Make sure the oven is plugged into a properly earthed electrical outlet.

(Continued on next page.)

How to Operate NE-1853/NE-1653



2. Open the door and leave it open.
The oven lamp will turn on. "0" will appear in the display. While touching Start Pad, touch Prog Pad until the Digital Display Window show "PROG" and "P" (for more than 2 seconds).



3. Program Lock feature is now deactivated.
Note: In "Program Unlock"
 - a. Oven reverts to a two-touch operating mode (Number/Memory Pad + Start Pad).
 - b. Repeat and interrupt features are operational.
 - c. Memory Pads can be programmed.
 - d. Manual heating is operational.
 - e. Tone loudness control, length control and pitch control (beep tone at the end of heating cycle/filter cleaning alarm) are operational.

L. To Read Program List

1. Open the door and leave it open.
2. While touching Start Pad, touch Number Pad "1".
All currently programmed information (the program set into each Number/Memory Pad (A0 to C9), Beep Tone, Program Lock, Oven Lamp settings when the door is open, Oven Lamp blink settings at the end of heating cycle and Oven Lamp reduction settings during cooking information) will continuously appear.
Note: When the filter cleaning alarm counter is set, this appears after Program Lock.

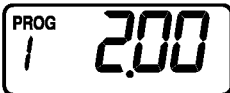

- How to erase memory content**
1. Open the door (keep it open) and touch Prog Pad.
 2. Select the memory number you want to erase, and touch Power Level Selector Pad.
 3. Touch Stop/Reset Pad, and "0" is displayed to indicate that memory is erased.
*Memory content is automatically erased if overwritten.

How to Operate NE-1853/NE-1653

To Select Pitch of Tone

There are 3 options for the pitch of tone at the end of the heating cycle.

●: Low, ●●: Normal (Factory Setting), ●●●: High



8. Within 3 seconds after touching Prog Pad at Step 7, touch Start Pad.
 - A. "PROG" will start to blink.
 - B. Current pitch of tone will be displayed.
 - C. The display changes to "●", "●●", and "●●●" each time Start Pad is touched and the settings change (Under the "bE" in "bEEP").



9. When the desired pitch of tone has been selected, touch Prog Pad again. "PROG" will stop blinking, and the set pitch of tone at the end of heating cycle will appear for 3 seconds. Then "0" will appear.



To proceed to set pitch of filter cleaning alarm, touch Start Pad before "0" is displayed after Step 9.

To Select Pitch of Filter Cleaning Alarm

There are 3 options for the pitch of the filter cleaning alarm.

●: Low, ●●: Normal (Factory Setting), ●●●: High



10. Within 3 seconds after touching Prog Pad at Step 9, touch Start Pad.
 - A. "PROG" will start to blink.
 - B. Current pitch of filter cleaning alarm will be displayed.
 - C. The display changes to "●", "●●", and "●●●" each time Start Pad is touched and the settings change (Under the "EP" in "bEEP").



11. When the desired pitch of filter cleaning alarm has been selected, touch Prog Pad again. "PROG" will stop blinking, and the set pitch of filter cleaning alarm will appear for 3 seconds. Then "0" will appear.



Note: When the programmed hour of cleaning Air Filter is "0", the pitch of filter cleaning alarm can not be selected.

N. Procedure to Program the Air Filter



1. Open the door and leave it open. The oven lamp will turn on. "0" will appear in the Digital Display Window.



2. While touching Start Pad, touch Number Pad "7".



3. The display will show the length of time (in hours) between cleaning the Air Filter you have programmed in or the original time preset by the manufacturer.



4. Set the desired time between cleaning by touching the appropriate Number Pads. (Up to 9999 hours)
[Example]: Touch Number Pads "6", "0" and "0" for 600 hours.

(Continued on next page.)

How to Operate NE-1853/NE-1653



5. Touch Prog Pad.
This completes the procedure to program time between cleaning of the Air Filter.



6. After 3 seconds, "0" will appear in the Digital Display Window. The oven is now ready for use.



- Note:** When "FILt" sign appears in Digital Display Window, remove the Air Filter and clean it.
Touch Stop/Reset Pad for 2 seconds to clear the display.

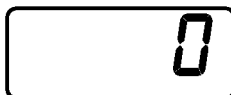

To display the filter cleaning alarm counter

1. Open the door and leave it open.
2. While touching Start Pad, touch Number Pad "5".
3. The cumulative total cooking time starts over and is displayed after it is cleared.

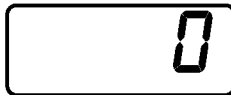

After 3 seconds, "0" will appear in the Digital Display Window.

N.B. If the oven cuts out after short operation, check the Air Filter is clean before calling an engineer.

O. Oven Lamp

(The oven can not be programmed until the program lock feature is deactivated.)

•Oven Lamp settings when the door is open

To turn Oven Lamp settings OFF



1. Open the door and leave it open.
The oven lamp will turn on, and "0" will appear.



2. While touching Start Pad, touch Number Pad "9".
"PROG" will start to blink. The previously set Oven Lamp settings are displayed.



3. Touch Start Pad.
Note: "on" → "oFF" → "on" is repeated each time the Pad is touched.

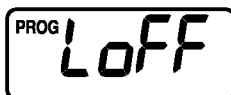

4. Touch Prog Pad.
"PROG" will stop blinking, and the Oven Lamp settings will appear for 3 seconds.
Then "0" will appear.

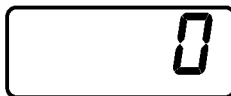

To proceed to Step 5, touch Start Pad before "0" is displayed after Step 4.

(Continued on next page.)

How to Operate NE-1853/NE-1653

•Oven Lamp blinks at the end of heating cycle

To turn the blinking Oven Lamp ON at the end of heating cycle



5. Within 3 seconds after touching Prog Pad at Step 4, touch Start Pad.
"PROG" will start to blink. The previously set Oven Lamp blink settings are displayed.



6. Touch Start Pad.
Note: "oFF" → "on" → "oFF" is repeated each time the Pad is touched.

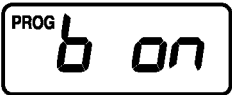

7. Touch Prog Pad.
"PROG" will stop blinking, and the Oven Lamp blink settings will appear for 3 seconds. Then "0" will appear.

To proceed to Step 8, touch Start Pad before "0" is displayed after Step 7.



•Adjusting Oven Lamp brightness during cooking

To decrease brightness of the inner cavity during cooking



8. Within 3 seconds after touching Prog Pad at Step 7, touch Start Pad.
"PROG" will start to blink. The previously set Oven Lamp reduction settings are displayed.

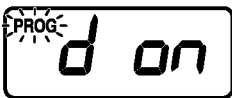

9. Touch Start Pad.
Note: "oFF" → "on" → "oFF" is repeated each time the Pad is touched.



10. Touch Prog Pad.
"PROG" will stop blinking, and the Oven Lamp reduction settings will appear for 3 seconds. Then "0" will appear.

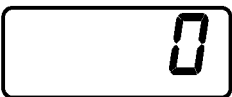





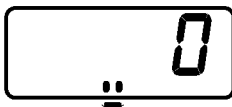
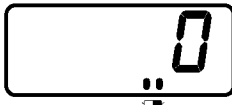

How to Operate NE-1843/NE-1643

Example: To cook food at MEDIUM power for 4 minutes



1. Make sure the oven is plugged into a properly earthed electrical outlet.

 2. Open the door.
The oven lamp will turn on. "0" will appear in the Digital Display Window and Power Level Indicator  will appear.
 3. Put the food into a suitable container, place it in the centre of the oven and then close the door securely.
The oven lamp will turn off.
Note: While "0" appears, operation is available. 1 minute after the door is closed, "0" will disappear.
 4. Press the desired Power Level Selector Button, if other than  (HIGH).
The selected Power Level Indicator will be displayed under the Digital Display Window.
[Example]: Press Power Level Selector Button once for  (MEDIUM).
 5. Set the desired heating time.
Please check the heating time will appear.
Note: The maximum set time for  is 25 minutes, and 30 minutes for  or .
[Example]: Set heating time for 4 minutes.
 6. Press Start Button.
A. The oven lamp will turn on.
B. Heating will start.
C. Power Level Indicator will start to blink.
D. The heating time on digital display will count down.
 7. When all time expires, beep tone will sound and all heating will stop.
The oven lamp will turn off. "0000" will blink until the door is opened. 1 minute later, cooling fan will stop.
 8. Open the door and take the food out.
The oven lamp will turn on. Digital Display Window will show "0" and Power Level Indicator  will appear.
 9. Close the door.
The oven lamp will turn off and 1 minute later, the Digital Display Window will go blank.
- When you press the Start Button with door open, "0" will appear in the display in all cases.
 - Even after setting the heating time you can still change the power level.
 - If you wish to change the heating time during heating, simply adjust the timer to desired minutes and seconds.

5 Test Mode

5.1. Component test procedure

CAUTION

1. High voltage is present at the high voltage terminal of the high voltage transformer during any cook cycle.
2. It is neither necessary nor advisable to attempt measurement of the high voltage.
3. Before touching any oven components, or wiring, always unplug the oven from its power source and discharge the high voltage capacitor.

1. High voltage transformer

- (A) Remove connections from the transformer terminals and check continuity.
- (B) Normal (cold) resistance readings should be as follows:

Secondary winding	Approx. 80 Ω ~ 120 Ω
Filament winding	Approx. 0 Ω
Primary winding	Approx. 0 Ω ~ 3 Ω

2. High voltage capacitor

- (A) Check continuity of capacitor with meter on highest OHM scale.
- (B) A normal capacitor will show continuity for a short time, and then indicate 9MΩ once the capacitor is charged.
- (C) A shorted capacitor will show continuous continuity.
- (D) An open capacitor will show constant 9MΩ.
- (E) Resistance between each terminal and chassis should be infinite.

3. Magnetron

Continuity checks can only indicate an open filament or a shorted magnetron. To diagnose for an open filament or shorted magnetron.

- (A) Isolate magnetron from the circuit by disconnecting the leads.
- (B) A continuity check across magnetron filament terminals should indicate one ohm or less.
- (C) A continuity check between each filament terminal and magnetron case should read open.

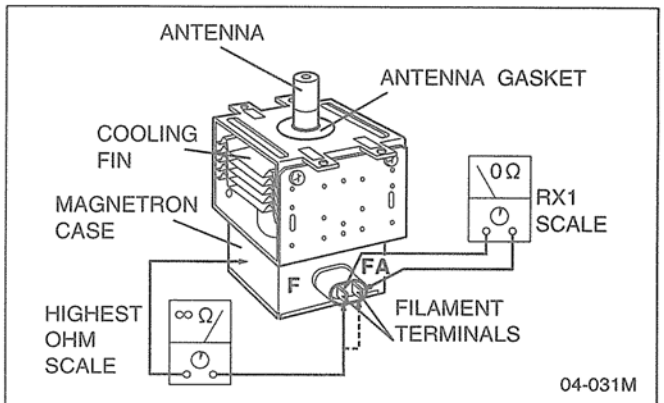
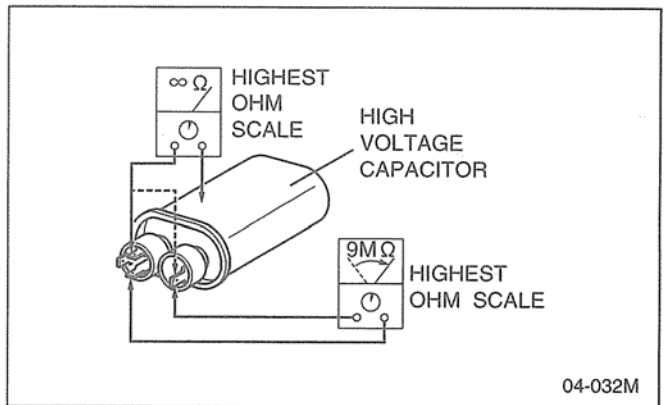
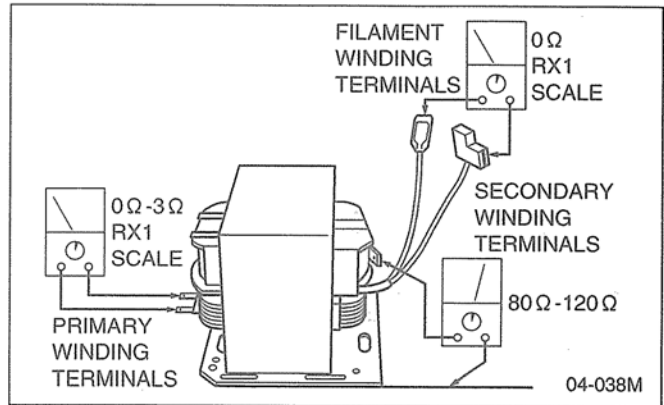

4. Diode

- (A) Isolate the diode from the circuit by disconnecting the leads.
- (B) With the ohmmeter set on the highest resistance scale, measure the resistance across the diode terminals. Reverse the meter leads and again observe the resistance reading. Meter with 6V, 9V or higher voltage batteries should be used to check the front-to-back resistance of the diode, otherwise an infinite resistance may be read in both directions. A normal diode's resistance will be infinite in one direction and several hundred k Ω in the other direction.

5. Membrane key board (Membrane switch assembly)

Check continuity between switch terminals, by tapping an appropriate pad on the key board. The contacts assignment of the respective pads on the key board is as shown in digital programmer circuit.

6. Protector diode

- (A) Isolate the protector diode assembly from the circuit by disconnecting its leads.
- (B) With the ohmmeter set on the highest resistance scale, measure the resistance across the protector diode terminals. Reverse the meter leads and again observe the resistance reading. A normal protector diode's resistance will be infinite in both directions. It is faulty if it shows continuity in one or both directions.

7. Temp sensor (Thermal protector)

A temp sensor is mounted on exhaust guide. Its purpose is to automatically shut off the oven in case the cavity overheats for any reason.

The thermal protector will operate at 257°F (125°C).

The device is connected to the DPC on touch control models.

When the thermal protector exceeds its temperature it will turn off the power to oven cavity and display will go to reset mode.

The cooking program can be reset after cool-down.

THERMISTOR RESISTANCE VALUE

30K-120K at 10°C-30°C (50°F-86°F)

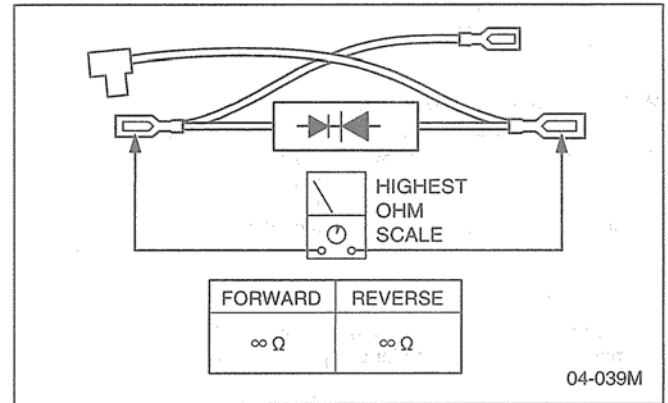
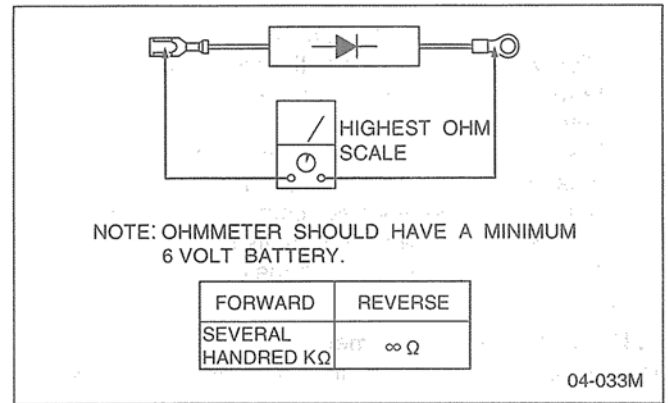

6 Troubleshooting Guide

6.1. Cautions to be observed when troubleshooting

Unlike many other appliances, the microwave oven is high-voltage, high-current equipment. Though it is free from danger in ordinary use, extreme care should be taken during repair.

CAUTION

Servicemen should remove their watches whenever working close to or replacing the magnetron.

1. Check the grounding

Do not operate on a 2-wire extension cord. The microwave oven is designed to be used when grounded. It is imperative, therefore, to make sure it is grounded properly before beginning repair work.

2. Warning about the electric charge in the high voltage capacitor

For about 30 seconds after the oven is turned off, an electric charge remains in the high voltage capacitor. When replacing or checking parts, remove the power plug from the outlet and short the terminal of the high voltage capacitor (terminal of lead wire from diode) to chassis ground with an insulated handle screwdriver to discharge.

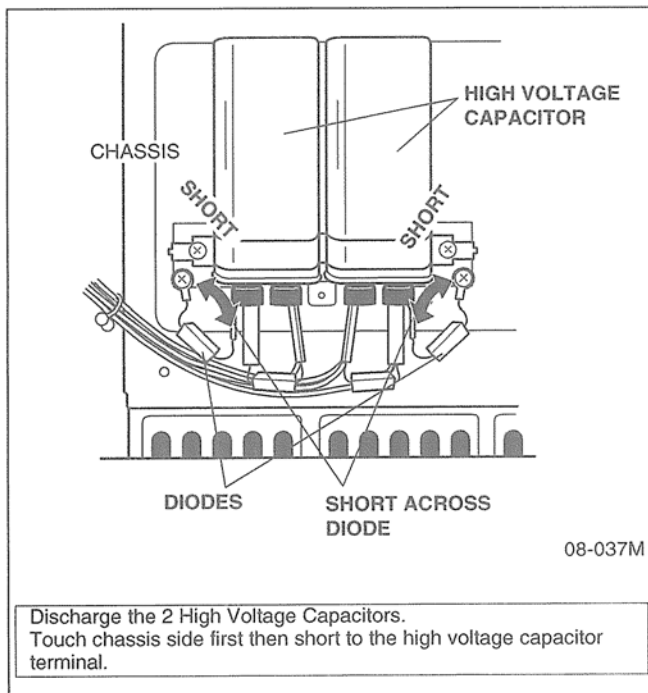

WARNING

There is high-voltage present, with high-current capabilities in the circuits of the high voltage winding and filament winding of the high voltage transformer. It is extremely dangerous to work on or near these circuits with oven energized. DO NOT measure the voltage in the high voltage circuit including filament voltage of magnetron.

WARNING

Never touch any circuit wiring with your hand nor with an insulated tool during operation.

3. When parts must be replaced, remove the power plug from the outlet.

4. When the 10A 250V fuse is blown due to the operation of short switch:

WARNING

When the 10A 250V. fuse is blown due to the operation of short switch, you must replace Primary latch switch and short switch. Also replace power relay (RY3 or RY4) when the continuity check reads shorted contacts (1-2).

- (A) This is mandatory. Refer to "Adjustments and Measurements" for these switches.
- (B) When replacing the fuse, confirm that it has the appropriate rating for these models.
- (C) When replacing faulty switches, be sure mounting tabs are not bent, broken or otherwise deficient in their ability to hold the switches.

5. Avoid inserting nails, wire, etc. through any holes in the unit during operation.

Never insert a wire, nail or any other metal object through the lamp holes on the cavity or any other holes or gaps, because such objects may work as an antenna and cause microwave leakage.

6. Confirm after repair

- (A) After repair or replacement of parts, make sure that the screws of the oven, etc. are neither loose nor missing. Microwaves might leak if screws are not properly tightened.
- (B) Make sure that all electrical connections are tight before inserting the plug into the wall outlet.

CAUTION

MICROWAVE RADIATION

DO NOT BECOME EXPOSED TO RADIATION FROM THE MICROWAVE GENERATOR OR OTHER PARTS CONDUCTING MICROWAVE ENERGY.

IMPORTANT NOTICE

1. The following components have potentials above 250V while the appliance is operated.

- ※ Magnetron
- ※ High voltage transformer
- ※ High voltage diode
- ※ High voltage capacitor
- ※ Protector diode

Pay special attention on these portions.

2. When the appliance is operated with the door hinge or magnetron fixed incorrectly, the microwave leakage can reach more than 5mW/cm². After repair or exchange, it is very important to check if magnetron and the door hinge is correctly fixed.

6.2. Troubleshooting guide

CAUTION

1. Check grounding before checking for trouble.
2. Be careful of the high voltage circuit.
3. Discharge high voltage capacitor.
4. When checking the continuity of the switches or the high voltage transformer, disconnect one lead wire from these parts and then check continuity with the AC plug removed. To do otherwise may result in a false reading or damage to your meter.

When disconnecting a plastic connector from a terminal, you must hold the plastic connector instead of the lead wire and then disconnect it, otherwise lead wire may be open or the connector cannot be removed.

5. Be sure to ground any static electric charge built up in your body, before handling the D.P.C.
6. A 220-240V AC is present at the shaded area  of the power supply circuit board (Terminals of power relays and primary circuit of low voltage transformer). When troubleshooting, be cautious of possible electrical shock hazard.

First of all operate the microwave oven following the correct operating procedures described on pages 4 ~ 8 of this service manual in order to find the exact cause of any trouble.

NOTE: If the unit shows faulty symptom as shown below, check the parts listed in possible cause column depending on failure indication e.g. F81, F82 in the display.

[TROUBLE 1] Oven does not operate at all or oven does not start cooking.

DISPLAY	CONDITIONS	POSSIBLE CAUSE	TIMING OF FAILURE INDICATION
F33	Open temperature sensor (exhaust)	1.Temperature sensor failure 2.Digital programmer circuit failure 3.Loose connector CN4	It is appeared when failure occurred.
F34	Short temperature sensor (exhaust)	1.Temperature sensor failure 2.Digital programmer circuit failure	It is appeared when failure occurred.
F44		1.Shorted membrane switch 2.Digital programmer circuit failure	It is appeared 2 minuted after failure occurred.
F01 (With continuous beep sounds)	Exhaust temperature exceeds 120°C	1.Burning food in the oven due to over cooking	It is appeared when exhaust temperature exceeds above 120°C
F05	Memory failure	1.Digital programmer circuit failure	
No display	2.5A fuse blown	1.Switch failure SW4, SW5, SW6, SW7 2.Low voltage transformer failure	
No display	2.5A fuse is OK	1.Switch failure SW1, SW2, SW3 2.Low voltage transformer failure 3.Digital programmer circuit failure	
F81	No voltage supply to high voltage transformer (upper)	1.Relay failure RY-3 2.Switch failure SW4, SW5 3.10A fuse open 4.Digital programmer circuit failure	It is appeared when cooking is completed.
F82	No voltage supply to high voltage transformer (lower)	1.Relay failure RY-4 2.Switch failure SW6, SW7 3.10A fuse open 4.Digital programmer circuit failure	It is appeared when cooking is completed.
F86	Shorted contacts of RY-3 and RY-5	1.Relay failure RY-3 and RY-5 2.Digital programmer circuit failure	It is appeared when failure occurred.
F87	Shorted contacts of RY-4 and RY-5	1.Relay failure RY-4 and RY-5 2.Digital programmer circuit failure	It is appeared when failure occurred.

7 Disassembly and Assembly Instructions

CAUTION

Servicemen should remove their watches whenever working close to or replacing the magnetron.

1. Replacement of magnetrons (Upper and Lower)

Upper magnetron

- (A) Discharge electric charge remaining on the high voltage capacitors.
- (B) Remove the entire rear panel by removing screws as shown.
- (C) Disconnect all lead wires from magnetron and thermal cutout.
- (D) Remove the 4 screws holding magnetron.
- (E) Remove 2 screws holding thermal cutout.
- (F) Remove the mounting bracket from magnetron and install it on the new magnetron.

Lower magnetron

- (A) Discharge electric charge remaining on the high voltage capacitors.
- (B) Remove the entire rear panel by removing screws as shown.
- (C) Carefully place the unit on its left side (H.V.Capacitor side).
- (D) Remove the cover by removing 2 screws.
- (E) Remove the 4 screws holding magnetron by inserting screwdriver through the 4 openings on bottom plate.
- (F) Remove 2 screws holding thermal cutout.
- (G) Remove the mounting bracket from magnetron and install it on the new magnetron.

NOTE: To prevent microwave leakage, tighten mounting screws properly making sure there is no gap between the waveguide and the magnetron.

CAUTION

When connecting 2 filament lead wires to the magnetron terminals, be sure to connect the lead wires in the correct position. The lead wire with blue connector should be connected to "FA terminal" and white or pink one should be connected to "F terminal".

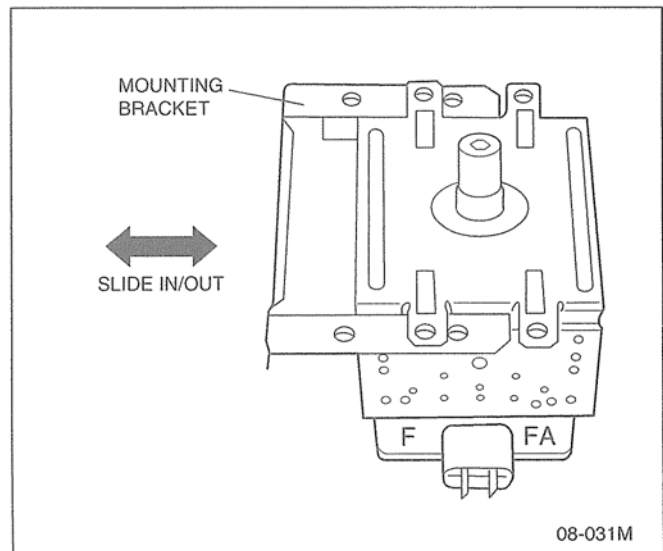
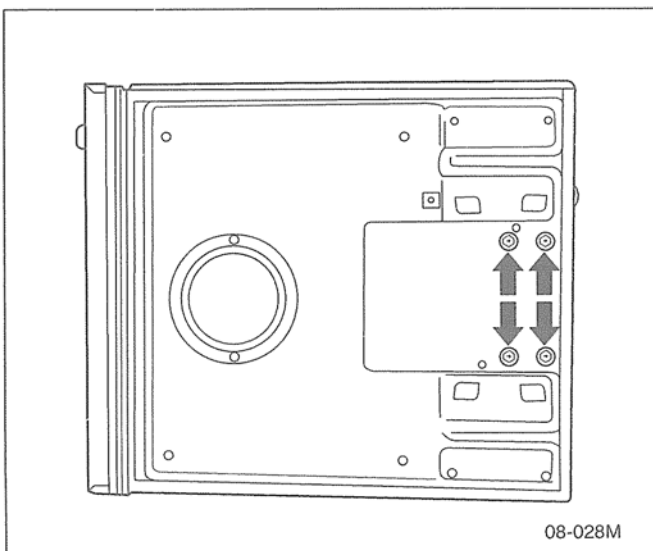
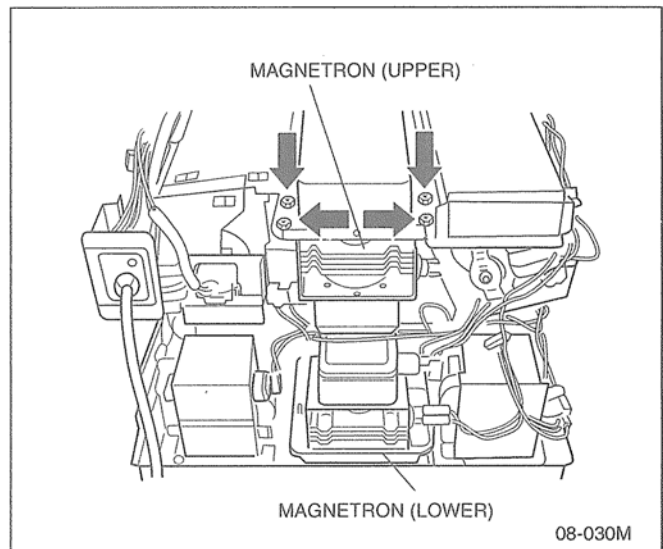
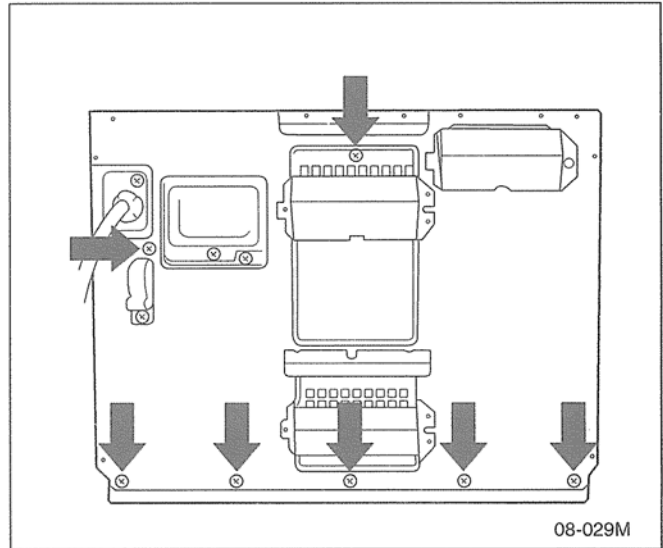

Removal of Positive Lock connector

The positive lock connector is a specially designed loose free connector and you will find this connector in many lead wire connections. To remove this connector, pull the lead wire by pressing an extruded lever in the center of receptacle terminal as shown.

2. Replacement of power supply circuit board

NOTE: Be sure to ground any static electric charge built up on your body, before handling the power supply P.C.B., PC Board B and D.P.C..

- (A) Disconnect all lead wires from power supply circuit board.
- (B) Remove the power supply P.C.B. together with its mounting bracket by first removing the 2 bracket holding screws.
- (C) The power supply P.C.B. can be separated from mounting bracket by removing the 2 L.V.T. holding screws and unfastening the plastic clips.

3. Replacement of PC Board B

- (A) Remove grounding screw for membrane switch and D.P.C. ground.
- (B) Remove 3 screws holding control panel assembly to detach it from main unit then remove connectors.
- (C) Remove 1 screw holding the PC Board B and while pushing back on 2 plastic holding clips, remove the board.

4. Replacement of digital programmer circuit

- (A) Disconnect all connectors connected to the D.P.C. board.
 - (B) Remove 5 screws holding the D.P.C. board and detach it.
- NOTE:** Please use care in handling the power supply P.C.B., PC Board B and D.P.C. board to avoid damage.

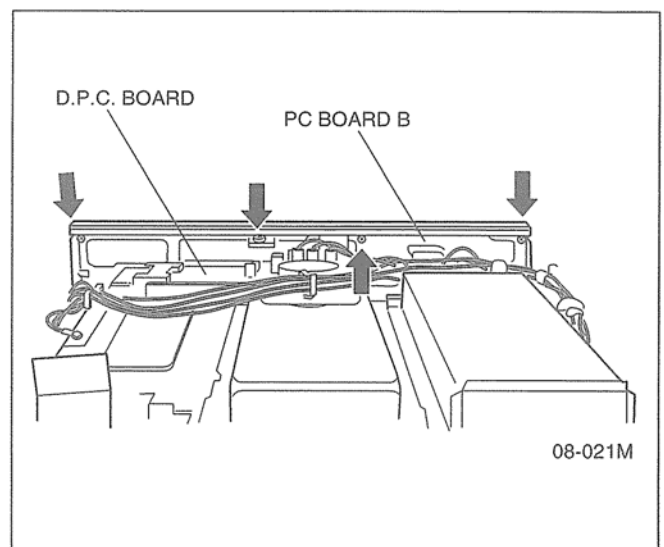
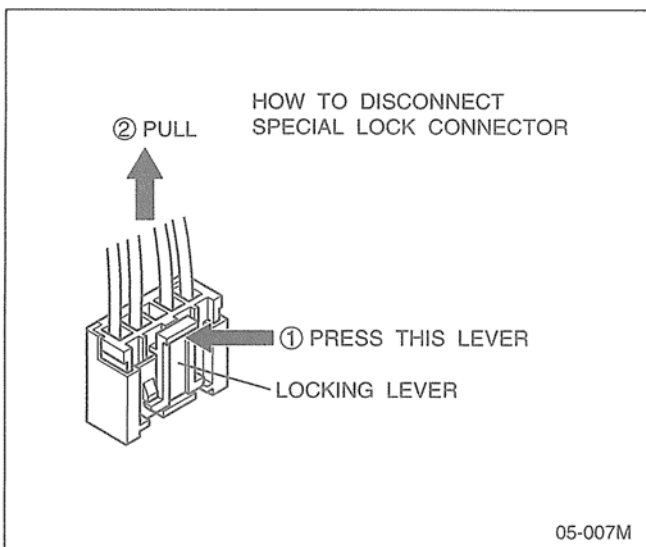
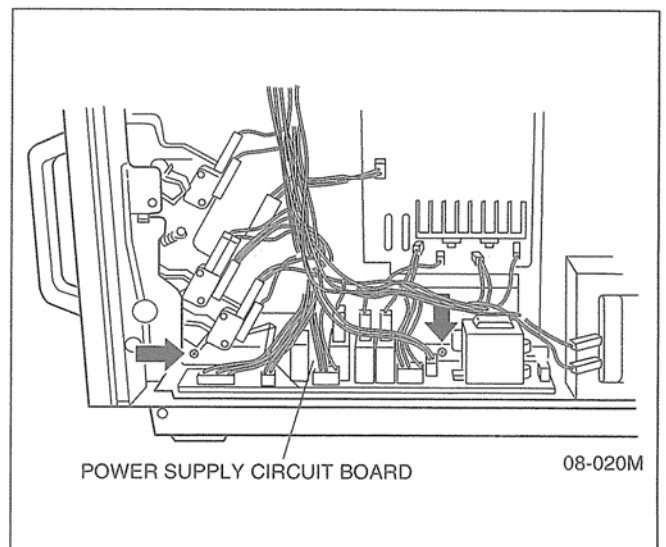
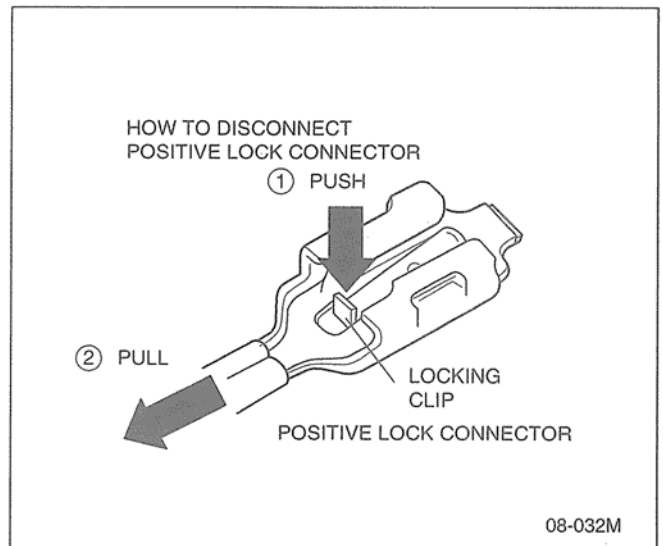

5. Replacement of upper antenna

CAUTION

The upper and lower rotating antennas are different type and are not interchangeable each other. Care should be taken not to reverse the top and bottom antennas.

- (A) Remove ceiling plate by gently moving the left and right tabs inward while pulling the plate down and outward.
- (B) Using a small flat screwdriver or the like, remove two plastic clips located on the antenna ring. Next turn the antenna ring approx. 1/8 turn clockwise to unhook the tabs and pull off.

6. Replacement of floor shelf and lower antenna

- (A) To remove the floor shelf, insert a screwdriver through the small opening on the left side of the oven cavity and carefully lift the floor shelf.
- (B) For removal of lower antenna, use the same procedure as upper antenna.

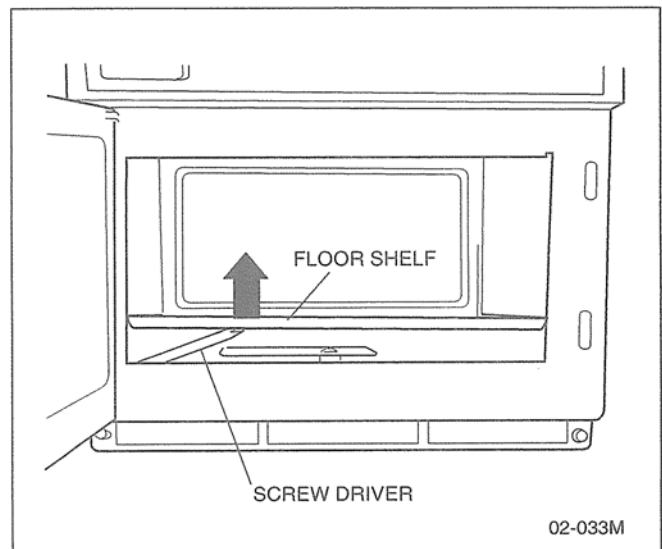
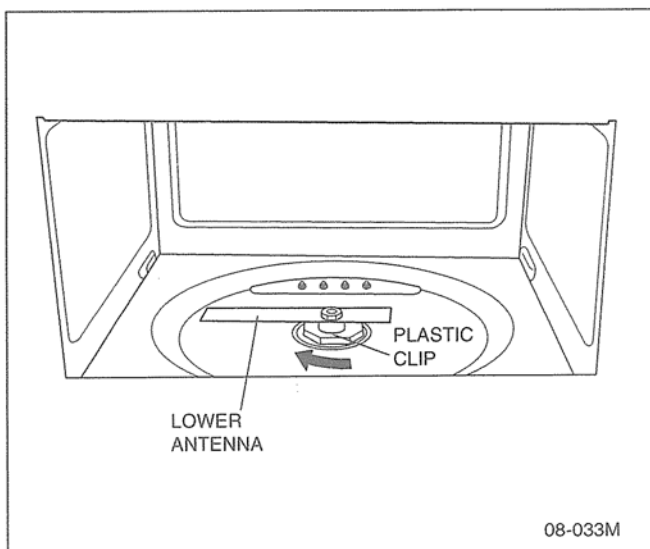
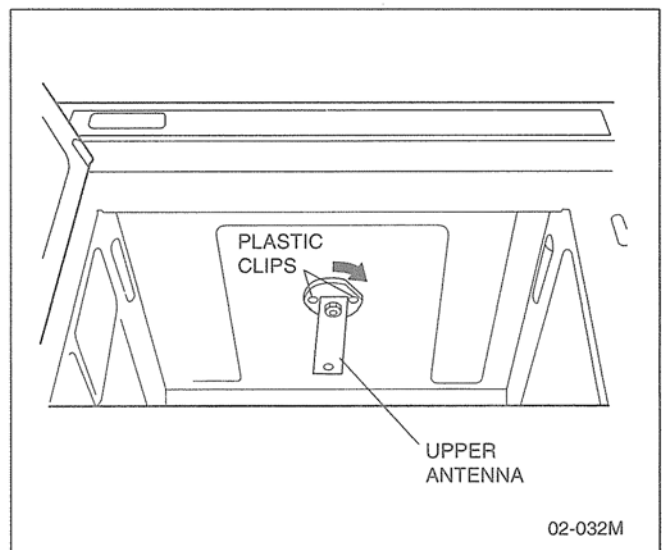
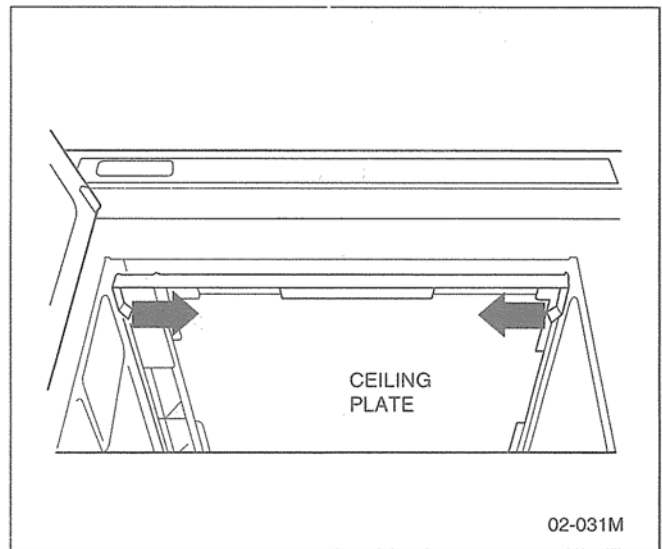

7. Replacement of temperature sensor (Thermal protector)

- (A) Cut 2 lead wires at the top of sensor terminals.
- (B) Remove 2 screws holding temp sensor and replace with new one.
- (C) Solder the lead wires securely to the sensor terminals.

8. Disassembly of door assembly

- (A) Remove each 2 bolts holding upper and lower hinges.
- (B) Open the door and while pulling the door outward, work upper and lower hinges out through the holes of the front surface of oven.
- (C) Remove door C (choke cover) from door E by carefully pulling outward starting from the upper right hand corner.
- (D) Remove 2 screws holding door handle and separate door A from door E by carefully freeing catch hooks.
- (E) Remove door key, door key lever, door key spring and handle pins from door E.
- (F) Assemble the door by taking the above steps in a reverse order.

Replacement

- (A) When mounting the door to the oven be sure to adjust the door parallel to the bottom line of the oven face plate by moving the upper and lower hinges in the direction necessary for proper alignment.
- (B) Adjust so that the door has no play between the inner door surface and oven front surface. If the door assembly is not mounted properly, microwave may leak from the clearance between the door and the oven.

NOTE: Please refer to MEASUREMENTS AND ADJUSTMENTS.

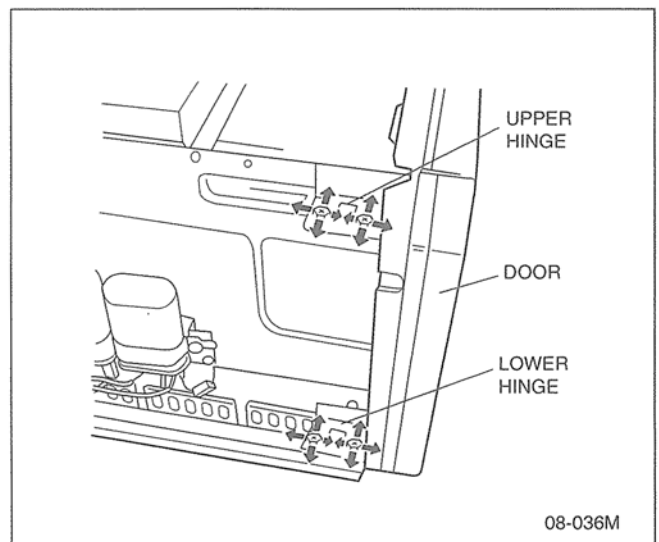
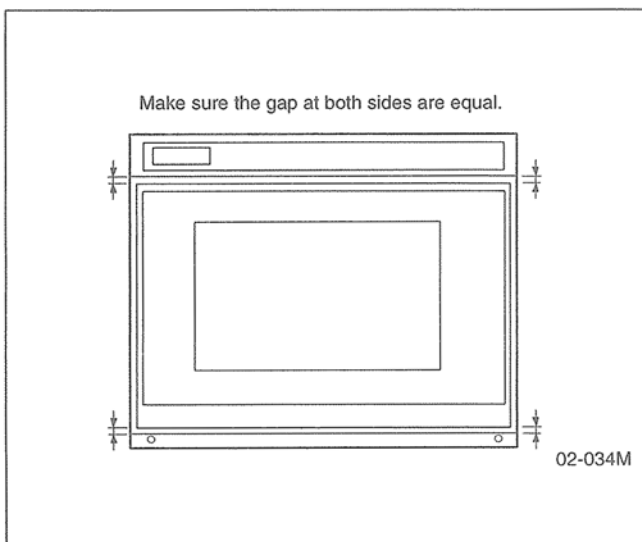
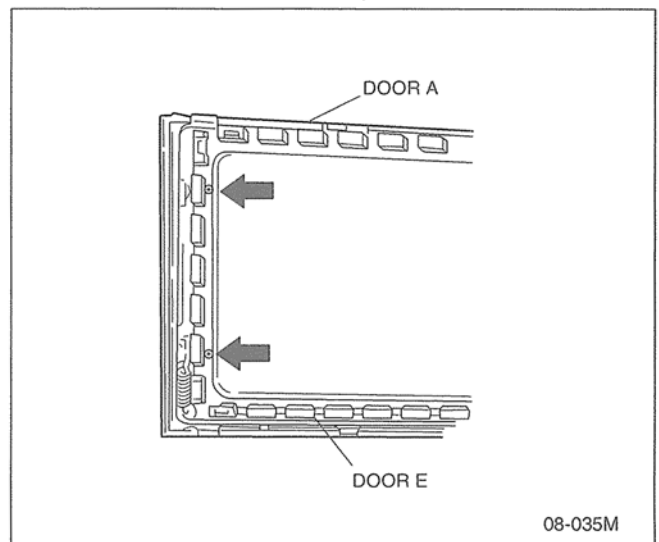
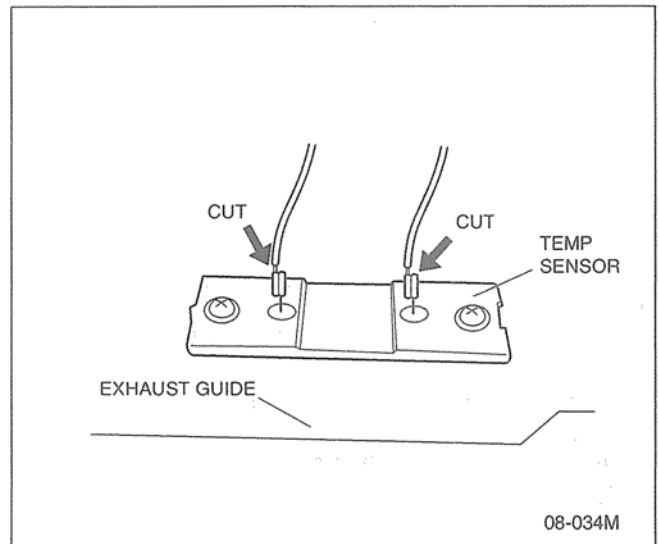

8 Measurements and Adjustments

8.1. Measurements and adjustments

1. Adjustment of safety switch A, safety switch B and short switch

(A) When mounting safety switch A, safety switch B and short switch to door hook assembly, mount each switch to the door hook assembly as shown in Figure right.

NOTE: No specific adjustment during installation of safety switch A, safety switch B and short switch to the door hook is necessary.

(B) When mounting the door hook assembly to the oven assembly, adjust the door hook assembly by moving it in the direction of arrow in table so that the oven door will not have any play in it. Check for play in the door by pulling the door assembly. Make sure that the latch keys move smoothly after adjustment is completed. Completely tighten the screws holding the door hook assembly to the oven assembly.

(C) Reconnect the short switch and check the continuity of the monitor circuit and all latch switches again by following the COMPONENT TEST PROCEDURE.

2. Measurement of microwave output

The output power of magnetron can be determined by performing IEC standard test procedures. However, due to the complexity of IEC test procedures, it is recommended to test the magnetron using the simple method outlined below.

Necessary Equipment:

- * 1 liter beaker
- * Glass thermometer
- * Wrist watch or stopwatch

NOTE: Check the line voltage under load. Low voltage will lower the magnetron output. Take the temperature readings and heating time as accurate as possible.

(A) Fill the beaker with exactly one liter of tap water. Stir the water using the thermometer and record the beaker's temperature (recorded as T1).

(B) Place the beaker on the center of glass cook plate. Set the oven for High power and heat it for exactly one minute.

(C) Stir the water again and read the temperature of the beaker (recorded as T2).

(D) The normal temperature rise (T2-T1) at High power position for each model is as shown in table.

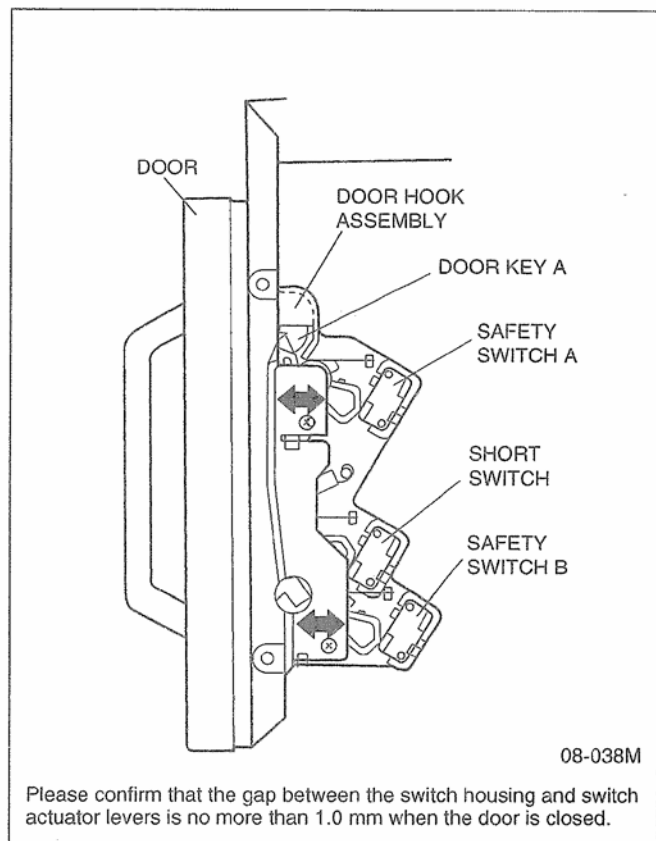
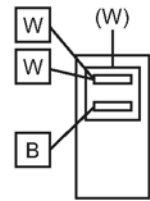
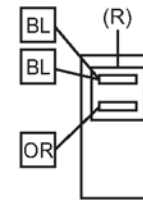
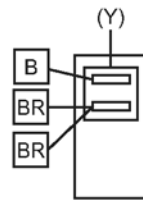
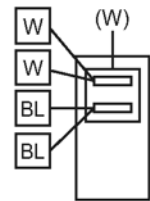
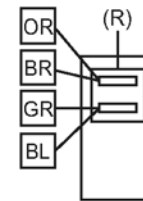
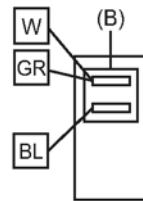
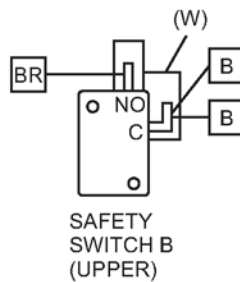
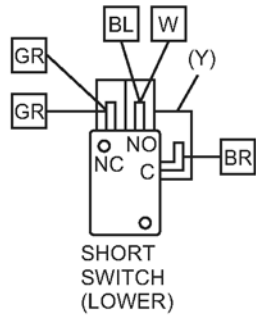
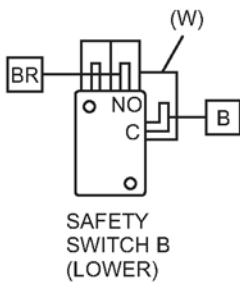
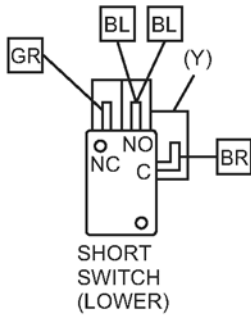
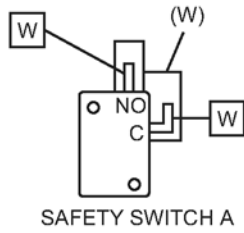
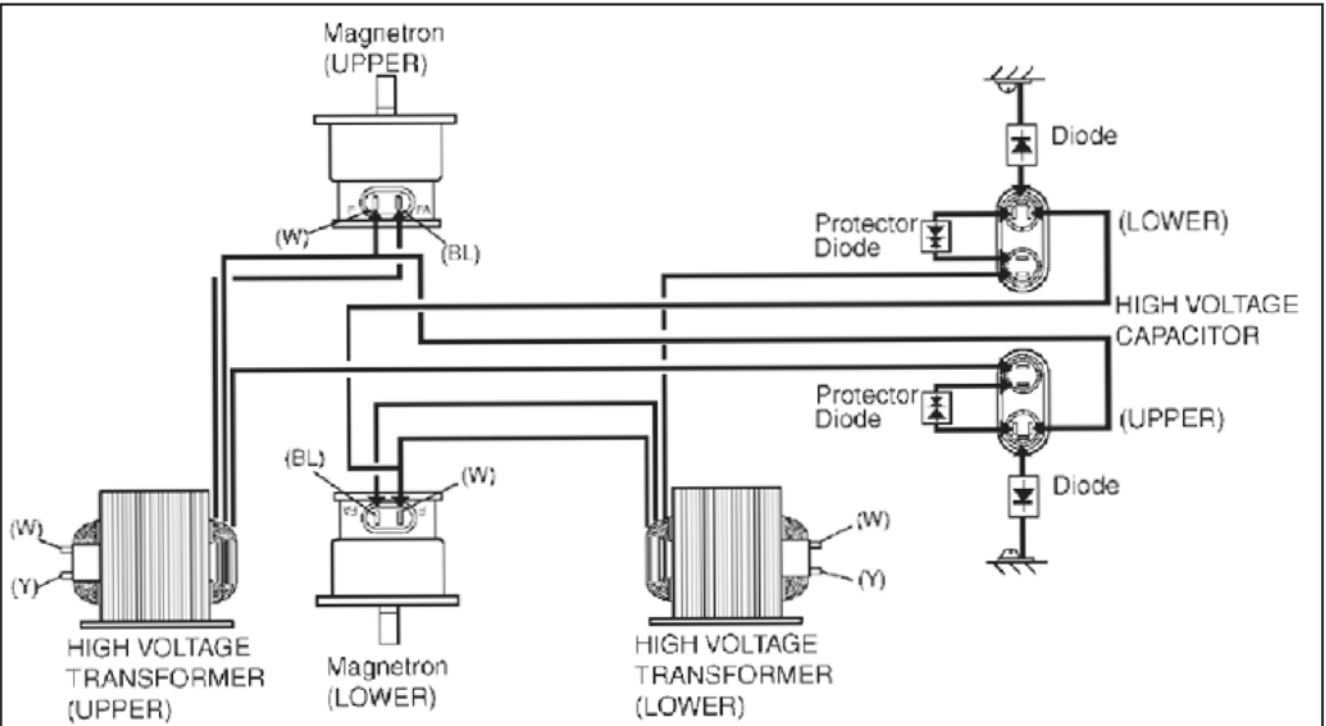

TABLE (1 l -1min. test)

RATED OUTPUT	TEMPERATURE RISE
1300W (IEC-705)	Min. 11.5°C
1400W (IEC-705)	Min. 12.5°C
1600W (IEC-705)	Min. 14.5°C
1700W (IEC-705)	Min. 15.0°C
1800W (IEC-705)	Min. 16.0°C

9 Wiring Connection Diagram

NOTE: When replacing, check the lead wire colour as shown.



SYMBOL	COLOUR
B	BLACK
R	RED
OR	ORANGE
GR	GRAY
BR	BROWN
Y	YELLOW
BL	BLUE
W	WHITE

M021

11 Exploded View and Replacement Parts List

11.1. Exploded view and parts list

NE-1853BPQ,NE-1843EUG,NE-1843BPQ,NE-1653EUG,NE-1643EUG

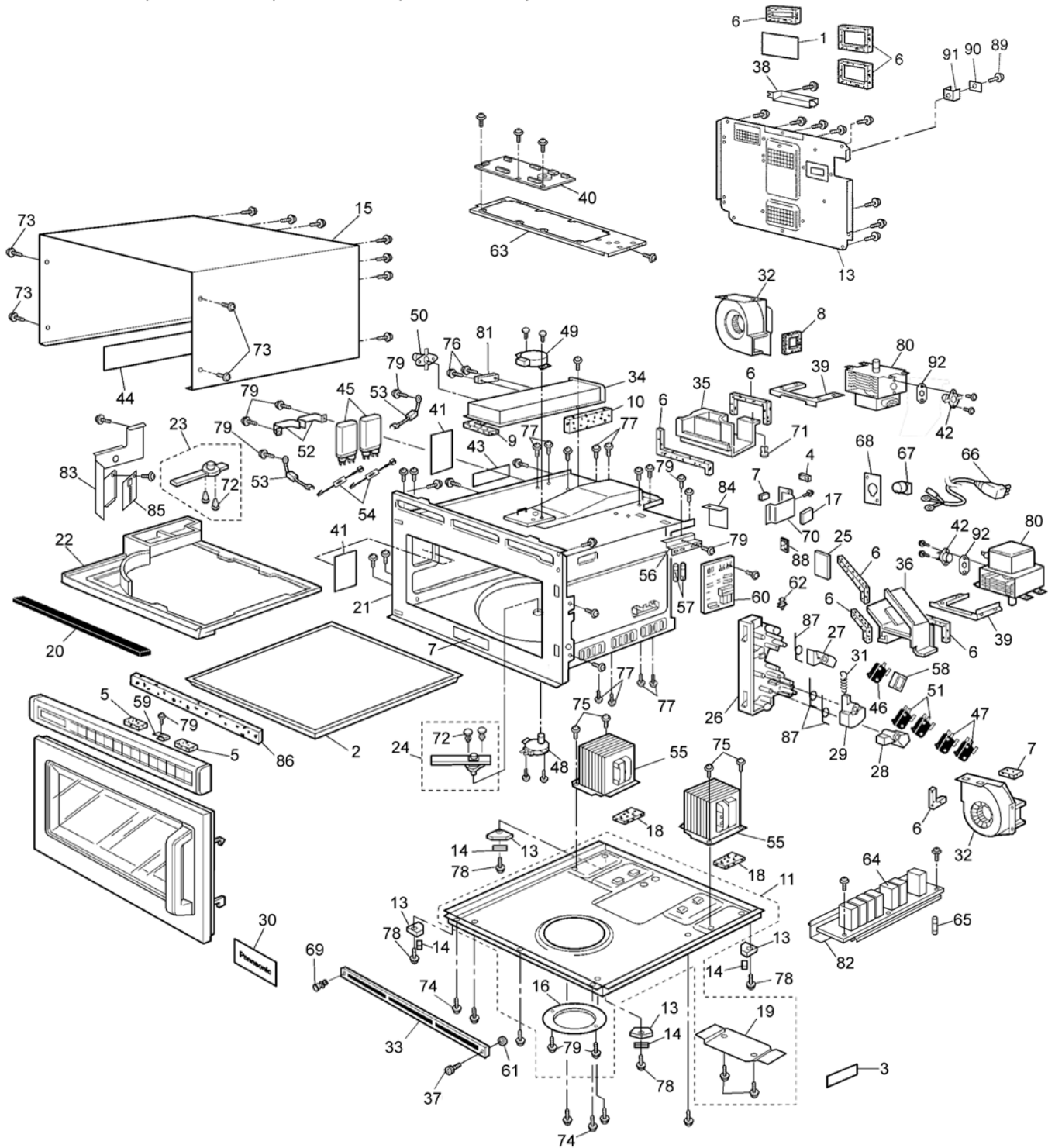

(S-3E8-APH)

PARTS LIST

NOTE 1: When ordering replacement part(s), please use part number(s) shown in this parts list.

Do not use description of the part.

2: Important safety notice:

Components identified by \triangle mark have special characteristics important for safety.

When replacing any of these components, use only manufacturer's specified parts.

3: Alphabet marks in Remarks columns (i.e. HNE etc) indicate parts applicable to only specified country models as follows.

BPQ : United Kingdom

EUG : Continental Europe Countries

Parts without these marks can be used for all models.

NE-1853BPQ,NE-1843EUG,NE-1843BPQ,NE-1653EUG,NE-1643EUG

Ref. No.	Safety	Part No.	Part Name & Description	Pcs/set	Remarks
1		A01723F90EU	CAUTION LABEL	1	
2		ANE010T8U0AP	SHELF	1	
3	\triangle	A05243G00EU	NAME PLATE	1	NE-1843EUG
3	\triangle	A05243F60EU	NAME PLATE	1	NE-1653EUG
3	\triangle	A05243F70EU	NAME PLATE	1	NE-1643EUG
3	\triangle	A05243F90BP	NAME PLATE	1	NE-1853BPQ
3	\triangle	A05243G00BP	NAME PLATE	1	NE-1843BPQ
4		ANE0901000CD	CUSHION RUBBER A	1	
5		ANE000Z000AD	CUSHION RUBBER C	5	
6		ANE000Z000AA	CUSHION RUBBER C	10	
7		ANE000Z000AD	CUSHION RUBBER C	4	
8		ANE000Z000AB	CUSHION RUBBER C	1	
9		ANE0962000AV	CUSHION RUBBER D	1	
10		ANE0962000AP	CUSHION RUBBER D	1	
11		A100A-3290	BASE	1	W/FOOT,RUBBER FOOT (NOTE 4)
12		A100Q3F90EU	BACK PANEL	1	
13		A1007-3280	FOOT	4	
14		A1008-3280	RUBBER FOOT	4	
15		A10093E80AP	CABINET BODY	1	
16		ANE10288U0AP	ANTENNA MOTOR COVER	1	
17		ANE10498U0AP	CUSHION RUBBER	1	
18		A10623E80AP	CUSHION RUBBER B	2	HVT
19		ANE11668U0AP	BASE METAL	1	
20		ANE11748U0AP	SPACER	1	
21	\triangle	A200A3F90EU	OVEN U	1	
22	\triangle	A2011-3280S	CEILING PLATE	1	
23		A202K-3850	ANTENNA UPPER (U)	1	
24		A202V3310GP	ANTENNA LOWER (U)	1	
25		ANE21208U0AP	SPACER	1	
26	\triangle	A3020-3850	DOOR HOOK	1	
27	\triangle	A3136-3470	HOOK SPACER A	1	
28	\triangle	A3138-3470	HOOK SPACER C	1	
29	\triangle	A3137-3850	HOOK SPACER B	1	
30		A31863G00EU	DOOR PANEL	1	NE-1843EUG, NE-1843BPQ
30		A31863F90BP	DOOR PANEL	1	NE-1853BPQ
30		A31863F60EU	DOOR PANEL	1	NE-1653EUG
30		A31863F70EU	DOOR PANEL	1	NE-1643EUG
31		ANE32398U0AP	SPRING	1	
32		A400A3F90EU	FAN MOTOR	2	
33		A400B-3280	AIR FILTER FRAME	1	
34		A400K-3180	EXHAUST GUIDE	1	
35		ANE40258U0AP	AIR GUIDE A	1	UPPER
36		ANE40268U0AP	AIR GUIDE B	1	LOWER
37		A4091-3280	SCREW	1	FOR AIR FILTER FLAME
38		A41073980AP	EXHAUST GUIDE B	1	
39		ANE50328U0AP	MAGNETRON BRACKET	2	
40	\triangle	A603L3G00BP	D.P.CIRCUIT (U)	1	NE-1843EUG, NE-1843BPQ
40	\triangle	A603L3F60EU	D.P.CIRCUIT (U)	1	NE-1653EUG
40	\triangle	A603L3F70EU	D.P.CIRCUIT (U)	1	NE-1643EUG
40	\triangle	A603L3F90BP	D.P.CIRCUIT (U)	1	NE-1853BPQ
41		ANE60408U0AP	OVEN LAMP SHEET	2	
42	\triangle	A61454210AP	THERMAL CUTOUT	2	FOR MAGNETRON

Ref. No.	Safety	Part No.	Part Name & Description	Pcs/set	Remarks
43		ANE60708U0BP	INSULATION SHEET A	1	
44		A60713310BP	INSULATION SHEET B	1	
45	⚠	A63903330GPS	H.V.CAPACITOR	2	NE-1843EUG, NE-1853-BPQ, NE-1843-BPQ
45	⚠	A63903430GPS	H.V.CAPACITOR	2	NE-1653EUG, NE-1643EUG
46	⚠	ANE61424L0AG	MICRO SWITCH	1	(V-16G-3C26) PRIMARY LATCH SWITCH
47	⚠	ANE6142-F60	MICRO SWITCH	2	(V-15G-3C26) SECONDARY LATCH SWITCH
48		A6144-3E20	ANTENNA MOTOR	1	(3W) LOWER
49		A6144-3E10	ANTENNA MOTOR	1	(3W) UPPER
50	⚠	A61454050AP	THERMAL CUTOUT	1	FOR OVEN
51	⚠	ANE6161-3X0	MICRO SWITCH	2	(V-16G-1C25) SHORT SWITCH
52		ANE61888U0AP	CAPACITOR BRACKET	2	
53	⚠	A6202-3280	DIODE,SI	2	
54	⚠	A606V3F00APS	PROTECTOR DIODE	2	
55	⚠	A622B3F90EU	H.V.TRANSFORMER	2	
56		ANE62298U0AP	MOUNTING BRACKET	1	
57	⚠	A62304210BP	FUSE	2	10A
58		A62383230GP	SPACER	1	
59		ANE64086Q0AP	SCREW WASHER	1	
60		A603Y3F90BP	PCB D(U)	1	
61		A6408-3280	WASHER	1	FOR AIR FILTER FRAME
62		ANE65448U0AP	SPACER A	1	
63		A6585-3B10	P.C.B.HOLDER	1	
64	⚠	A608B3F90BP	PCB M(U)	1	
65		A65953700BP	FUSE B	1	2.5A
66	⚠	A900C3340EU	AC CORO W/PLUG	1	NE-1843EUG, NE-1653EUG, NE-1643EUG
66	⚠	A900C3310BP	AC CORO W/PLUG	1	NE-1853BPQ, NE-1843BPQ
67		ANE9027510RN	CORD BUSHING	1	
68		A90353060GP	CORD BRACKET	1	
69		ANE90828U0AP	CLIP (BLACK)	1	FOR AIR FILTER FRAME
70		ANE91448U0AP	BRACKET	1	
71		ANE91628U0AP	CLIP B	1	FOR AIR GUIDE A
72		ANE900T8V0AP	CLIP	4	FOR ANTENNA (U),ANTENNA B (U)
73		XTC4+10BC	SCREW	4	4X10 (FOR CABINET BODY)
74		XTN4+12QJ	SCREW (BLACK)	2	4X12 (FOR BASE)
75		XTEA5+10BJ	SCREW	4	5x10 (FOR H.V. TRANSFORMER)
76		XTWANE3+8EX	SCREW	2	3X8 (FOR TEMP SENSOR)
77		XYEA5+C16TJ	SCREW	8	5X16 (FOR MAGNETRON)
78		XTW3+8BJ	SCREW	4	3X8 (FOR FOOT)
79		XYD4+EE12FJ	SCREW	11	4X12 (FOR DIODE,CAPACITOR BRACKET,SPACER,MOUNTING BRACKET,EARTH,ANTENNA MOTOR COVER,BASE METAL)
80	⚠	2M210-MLJ3F	MAGNETRON	2	
81	⚠	A601L5150AP	TEMP SENSOR	1	
82	⚠	A692R3F90BP	RELAY BRACKET U	1	
83	⚠	A6603-3E10	LAMP BRACKET	1	
84	⚠	A61713A80BP	INSULATION SHEET D	1	
85	⚠	A605S3E20P4	PCB H(U)	1	
86		A8251-3180	SPACER	1	
87		ANE32628U0AP	SPRING	3	
88		ANE1062-8U0	CUSHION RUBBER B	1	AIR GUIDE B
89		XYE6+F20FJ	SCREW	1	BACK PANEL COVER
90		XWNANE65GV	WASHER	1	EARTH
91		A66623170GP	BRACKET	1	EARTH
92		A62383F90WT	SPACER	2	

DOOR ASSEMBLY

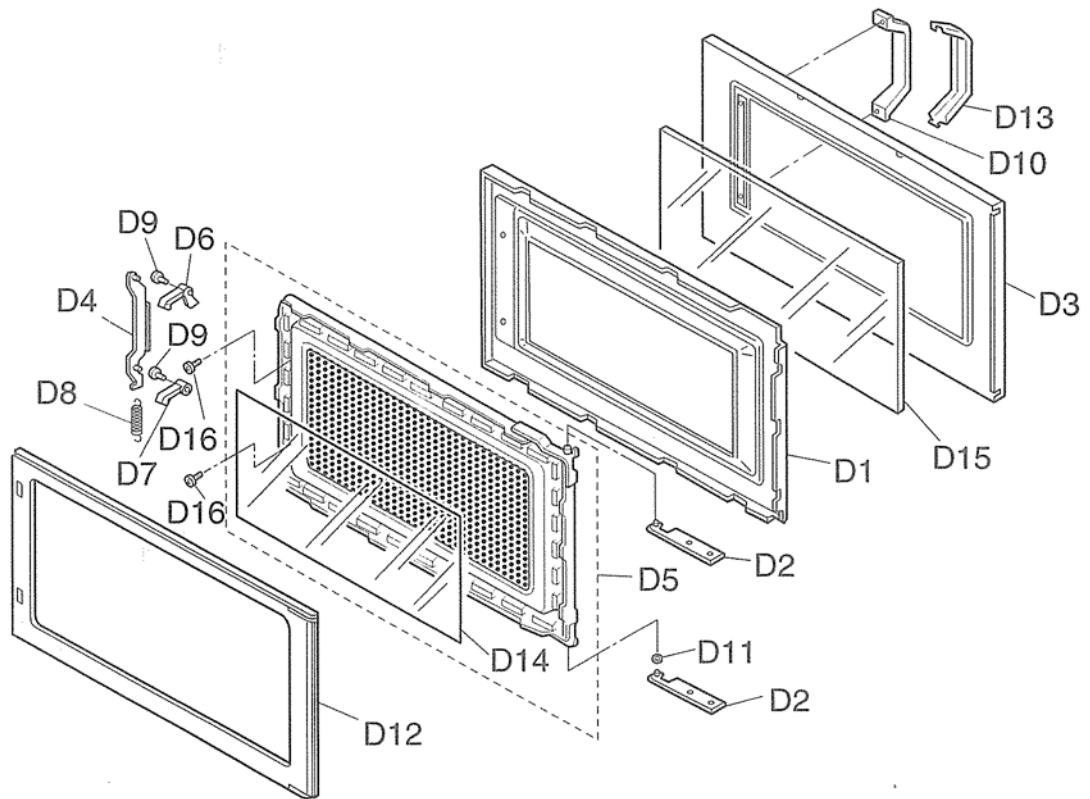

(S-331 QPQ)

Ref. No.	Safety	Part No.	Part Name & Description	Pcs/set	Remarks
D1		ANE30038U0AP	DOOR FRAME (U)	1	
D2	⚠	ANE30078U0AP	HINGE	2	
D3	⚠	ANE301A8U0AP	DOOR A	1	
D4		ANE301H-3850	DOOR KEY LEVER B	1	
D5	⚠	ANE301Q-3500	DOOR E (U)	1	
D6		ANE3018-3850	DOOR KEY	1	
D7		ANE3019-3850	DOOR KEY B	1	
D8		ANE30218U0AP	DOOR KEY SPRING	1	
D9		ANE30562Q0AP	HANDLE PIN	2	
D10		A30703170GP	HANDLE PEICE A	1	
D11		ANE3081P60AP	DOOR HINGE SPACER	1	
D12		ANE30858U0AP	DOOR C	1	
D13		ANE31348U0AP	HANDLE PEICE B	1	
D14	⚠	A3145-3500	DOOR SCREEN A	1	
D15		ANE31468U0AP	DOOR SCREEN B	1	
D16		XYEA4+C16TSJ	SCREW	2	4X16

ESCUTCHEON BASE ASSEMBLY
NE-1853BPQ, NE-1653EUG

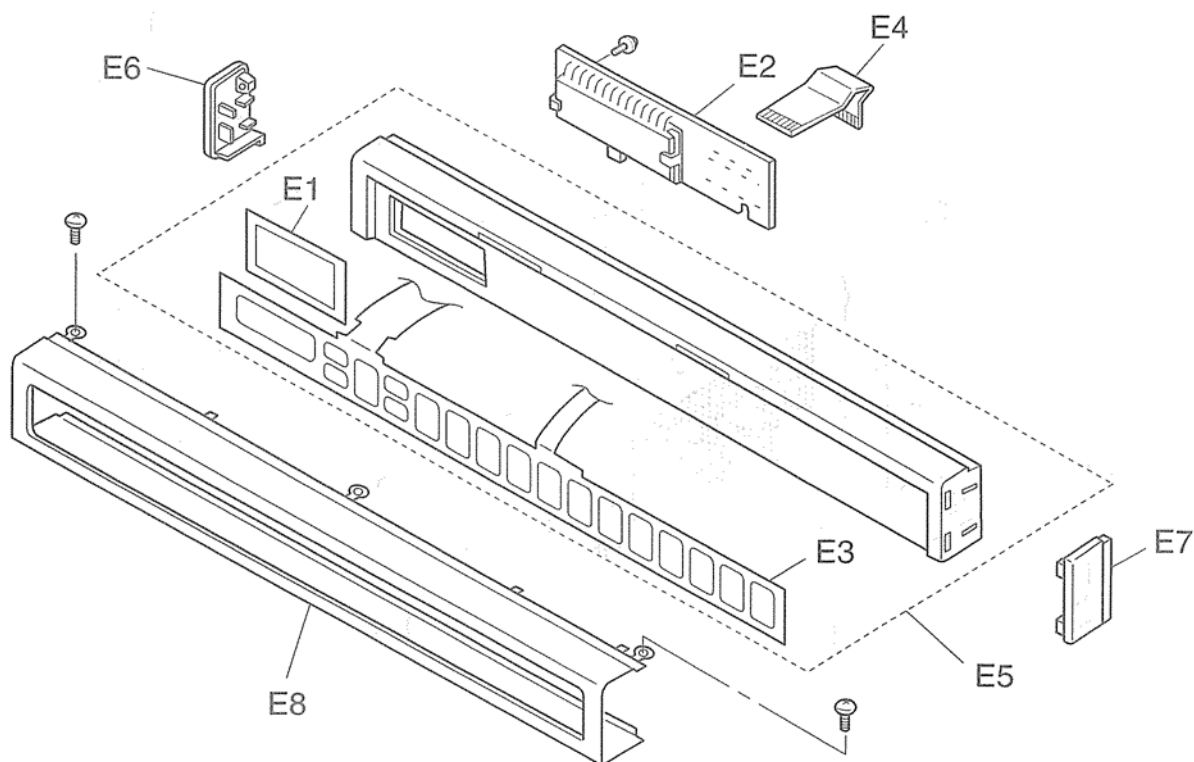

(S-331 QPQ)

NE-1853BPQ,NE-1653EUG

Ref. No.	Safety	Part No.	Part Name & Description	Pcs/set	Remarks
E1		A8016-3B10	SPACER	1	
E2		A603M-3B10	PC BOARD B (U)	1	
E3		A83373F90EU	ESCUTCHEON SHEET	1	
E4		A6590-3E20	FLAT CABLE	1	
E5		A800L3F90EU	ESCUTCHEON BASE U	1	
E6		A80023E20P3	ESCUTCHEON B	1	
E7		A80063E20P3	ESCUTCHEON D	1	
E8		ANE801N8U0AP	ESCUTCHEON A (U)	1	

NE-1843EUG, NE-1843BPQ, NE-1643EUG

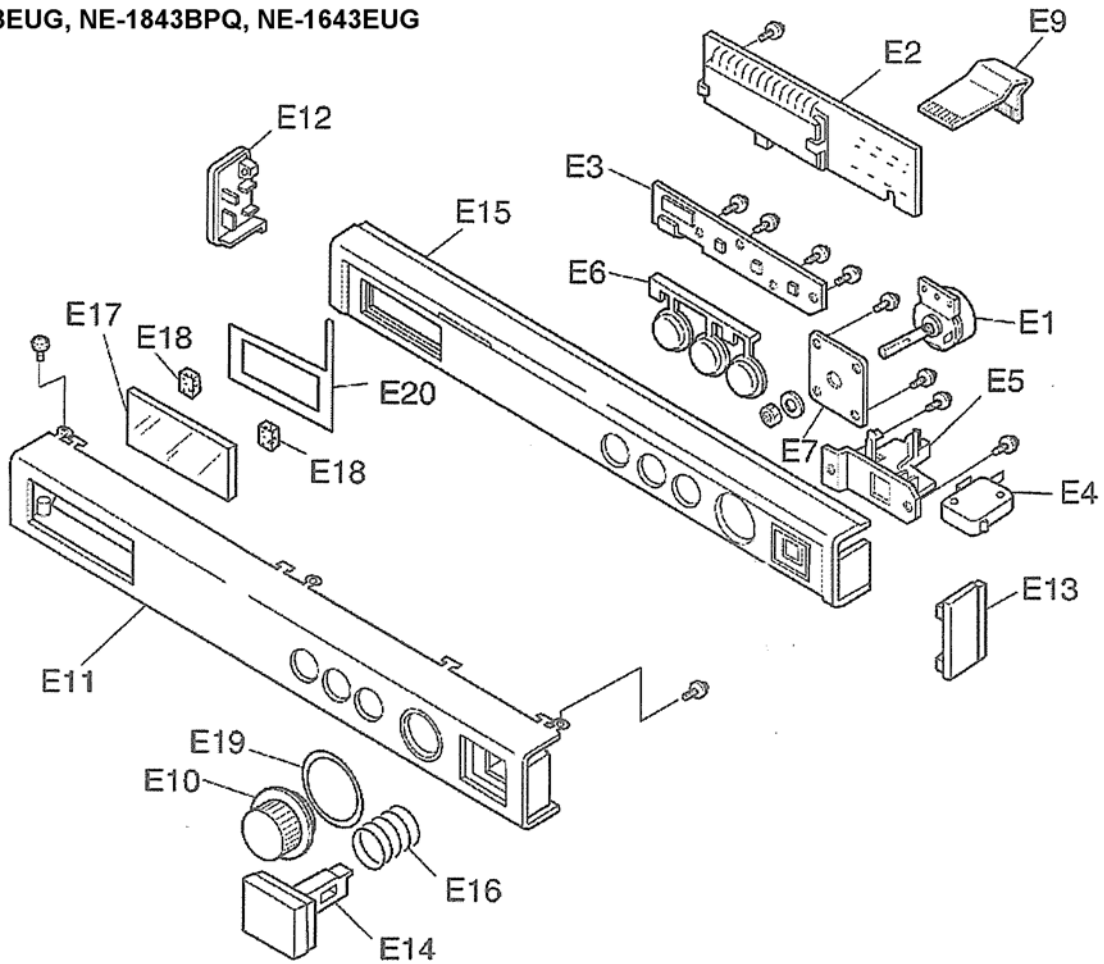

NE-1843EUG, NE-1843BPQ, NE-1643EUG

Ref. No.	Safety	Part No.	Part Name & Description	Pcs/set	Remarks
E1		A608C3G00BP	TIMER	1	
E2		A603M-3B10	PC BOARD B (U)	1	
E3		ANE605Q8Y0BP	PC BOARD F (U)	1	
E4		ANE61424LOAG	MICRO SWITCH	1	
E5		ANE61628Y0BP	START SWITCH BRACKET	1	
E6		ANE62648Y0BP	SELECT SWITCH BUTTON	1	
E7		A63433G00EU	TIMER BRACKET	1	
E9		A6590-3E20	FLAT CABLE	1	
E10		A800D3G00EU	TIMER KNOB	1	
E11		ANE80018Y0BP	ESCUTCHEON A (U)	1	
E12		A80023E20P3	ESCUTCHEON B	1	
E13		A80063E20P3	ESCUTCHEON D	1	
E14		ANE803X8Y0BP	START BUTTON	1	
E15		A80343G00EU	ESCUTCHEON BASE	1	
E16		ANE80378Y0BP	COOK BUTTON SPRING	1	
E17		A81263G00EU	SMOKE PANEL	1	
E18		ANE0921000BA	CUSHION RUBBER C	2	
E19		ANE82878Y0BP	SPACER A	1	
E20		A83373G00EU	ESCUTCHEON SHEET	1	

PACKING AND ACCESSORIES

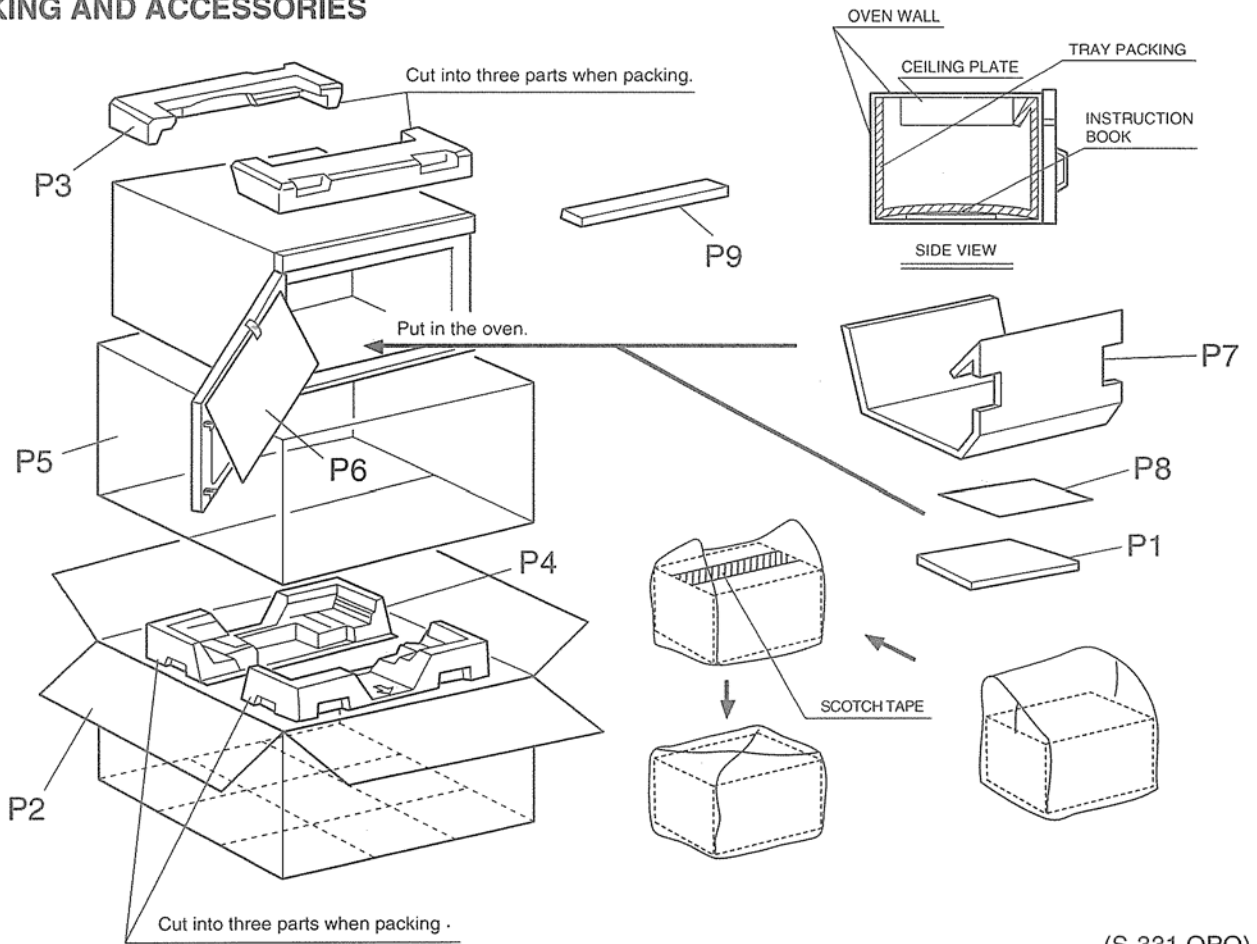

(S-331 QPQ)

Ref. No.	Safety	Part No.	Part Name & Description	Pcs/set	Remarks
P1	⚠	A00033F90EU	INSTRUCTION BOOK	1	NE-1843EUG, NE-1653EUG, NE-1643EUG
P1	⚠	A00033F90BP	INSTRUCTION BOOK	1	NE-1853BPQ, NE-1843BPQ
P2		A01023G00EU	PACKING CASE,PAPER	1	NE-1843EUG
P2		A01023F60EU	PACKING CASE,PAPER	1	NE-1653EUG
P2		A01023F70EU	PACKING CASE,PAPER	1	NE-1643EUG
P2		A01023F90BP	PACKING CASE,PAPER	1	NE-1853BPQ
P2		A01023G00BP	PACKING CASE,PAPER	1	NE-1843BPQ
P3		ANE01048U0AP	UPPER FILLER	1	
P4		ANE01058U0AP	LOWER FILLER	1	
P5		A01065200AP	VINYL COVER	1	
P6		ANE01072Q0AP	DOOR SHEET B	1	
P7	⚠	A01083310GP	TRAY PACKING	1	
P8		A04203F90BP	OPERATING GUIDE	1	NE-1853BPQ
P9		A01453230BP	DOOR SHEET B	1	

WIRING MATERIAL

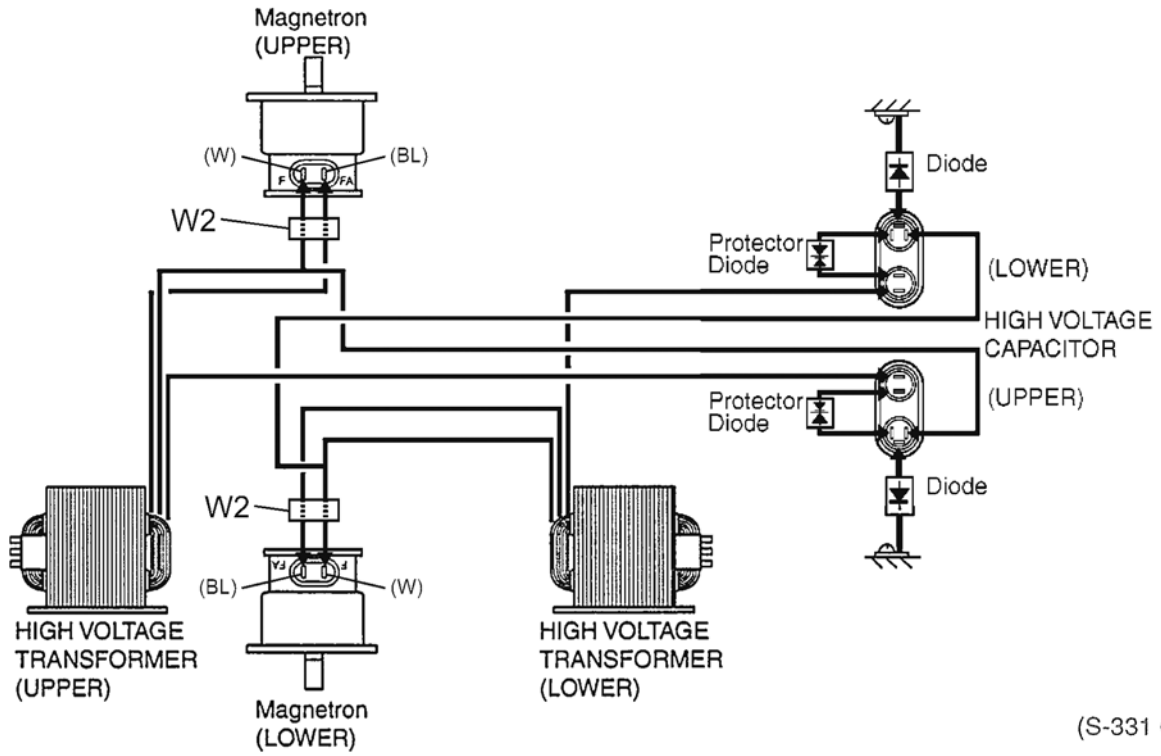
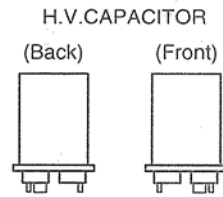
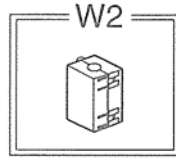
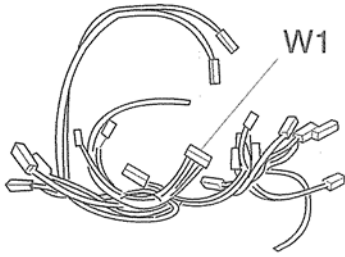

(S-331 QPQ)

Ref. No.	Safety	Part No.	Part Name & Description	Pcs/set	Remarks
W1	⚠	A030A3F90EU	LEAD WIRE HARNESS	1	
W2	⚠	A0KG00000169	FERRITE CORE	2	
W5		A0352-3280	LEAD WIRE	1	