

YBF9219GR

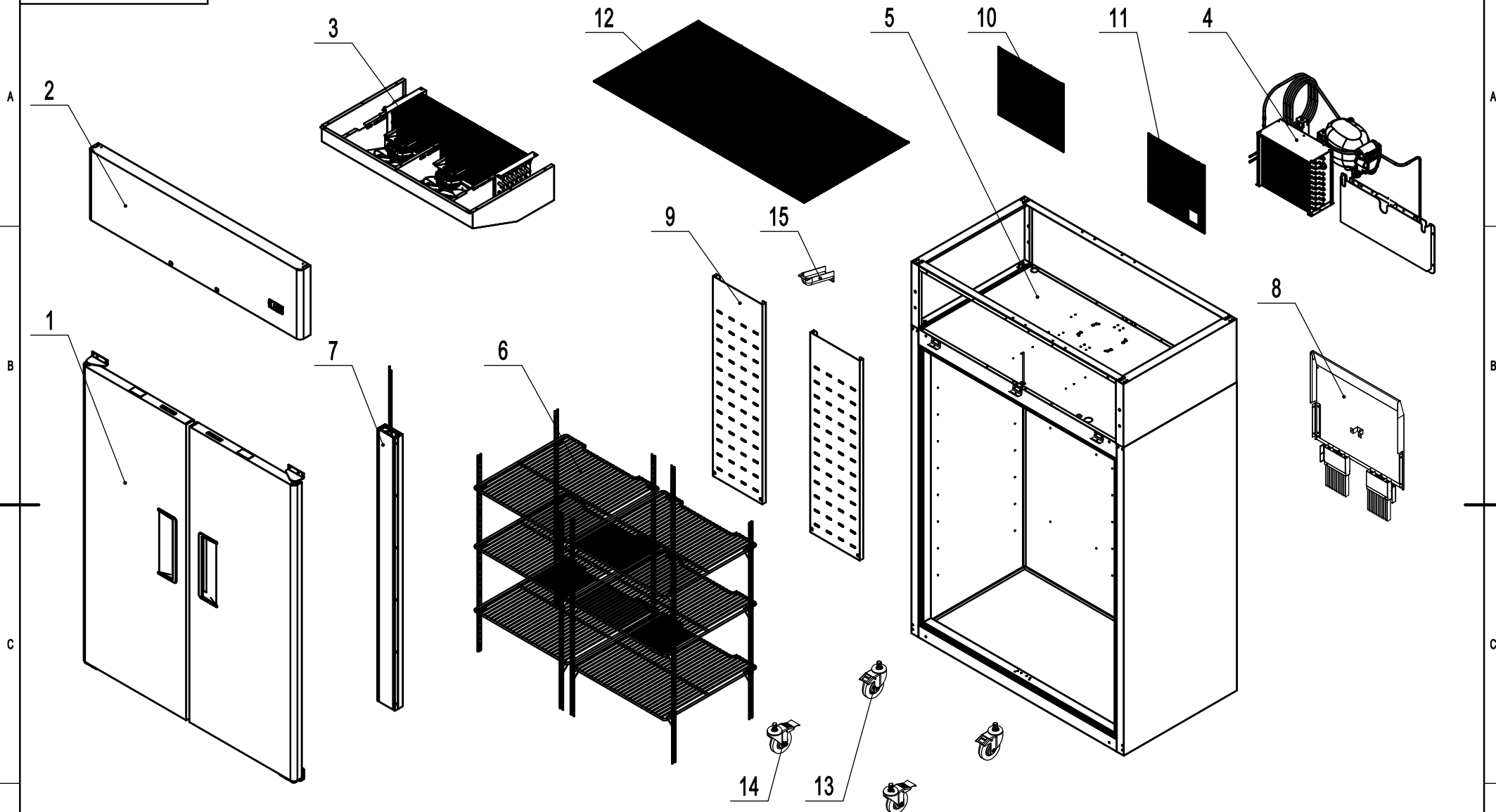

15	W0409081	A drain protection	排水管保护件	ABS	1		7	92180107	Mullion Assembly	中梁组件		1	
14	B0604421	4" Castor With Brake	4寸带刹车重磅万向轮(刹定向)		2		6	92180106	Shelf Assembly	食品架组件		1	
13	B0604413	4" Castor Without Brake	4寸重磅万向轮(脚轮)		2		5	92190105	Cabinet Assembly	箱体组件		1	
12	W0402693	At the top of the net	箱体顶部保护网		1		4	92190104	Comp&Cond Assembly	冷凝组件		1	
11	W0402694-2	The back right of the net	箱体后背保护网右		1		3	92190103	Evaporator Assembly	蒸发组件		1	
10	W0402694-1	The back left of the net	箱体后背保护网左		1		2	92180102	Top Panel Assembly	前罩组件		1	
9	92101026	Back wind deflector	后背导风板	SUS430	2		1	92180101	Soilid Door Assembly	门体组件		1	
8	80010455	Water evaporation assembly	水蒸发组件		1		序号	Material code	English Name	Chinese Name	MATERIAL	QUANTITY	Remark

92180101

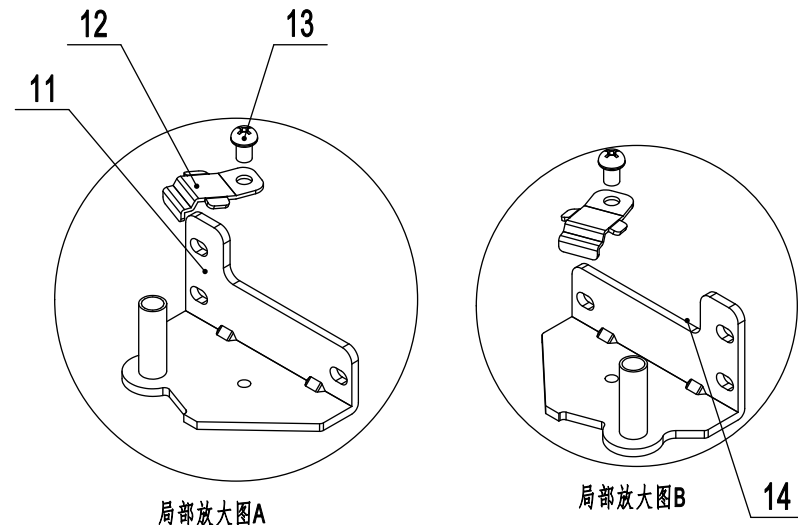
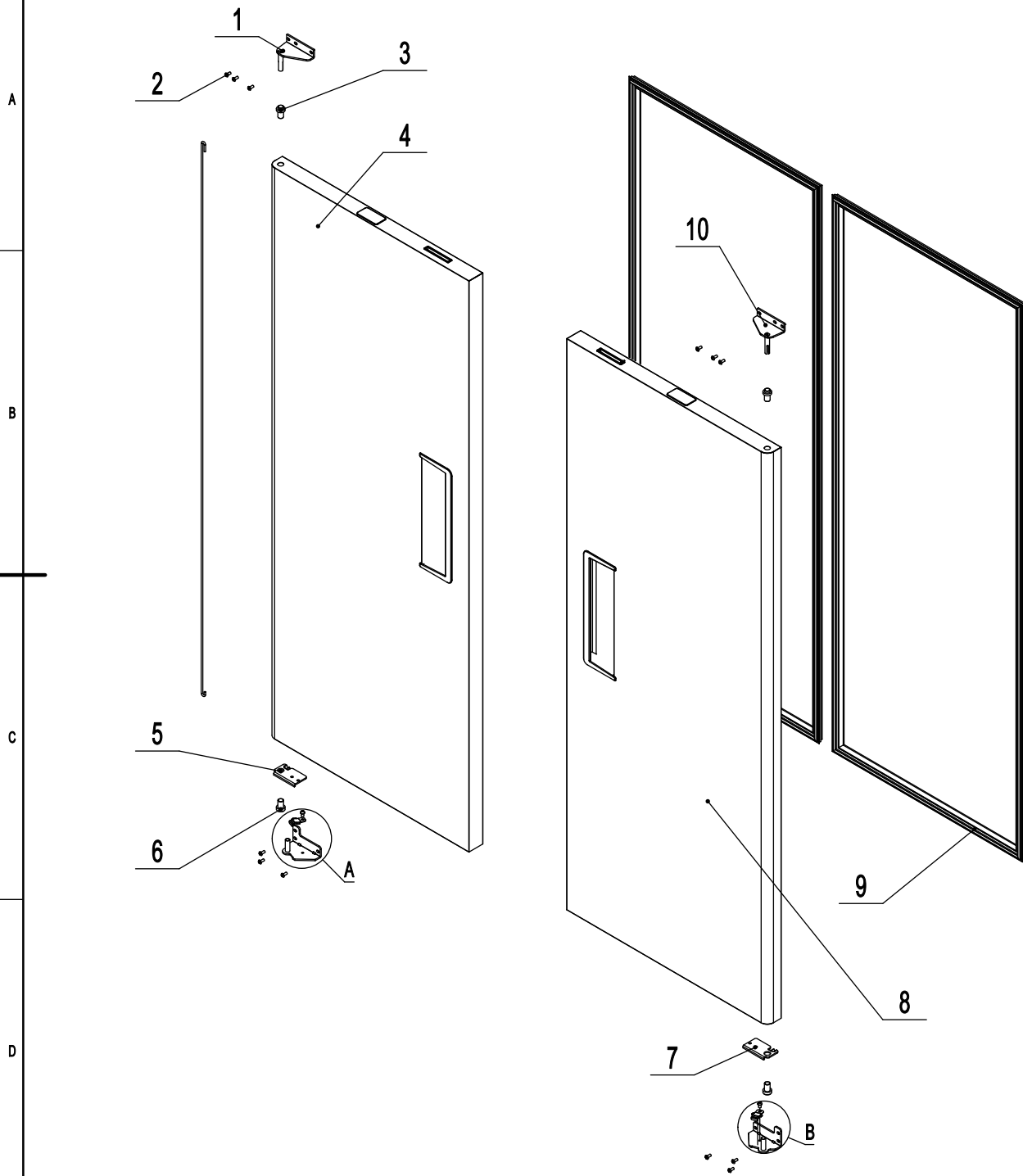

15	W0604944	Door Spring Bar	门体发条		2	
14	W0604037	Right-Bottom Hinge	右下铰链	SUS304	1	
13	B0507015	SS Screw M6x8	M6x8不锈钢螺丝		2	
12	W0604038	Door Brake-Bottom	门自锁装置-下	SUS304	2	
11	W0604036	Left-Bottom Hinge	左下铰链	SUS304	1	
10	W0604033	Right-Top Hinge	右上铰链	SUS304	1	
9	W0404904	Door Gasket	门封条		2	
8	92180224	Right Door	右门体		1	
7	W0604030	Door Brake -Left	门自锁装置-右	SUS304	1	
6	W0409843	Door Shaft Sleeve-Bottom	门体轴套	PA66	2	
5	W0604031	Door Brake -Right	门自锁装置-左	SUS304	1	
4	92180225	Left Door	左门体		1	
3	W0409842	Door Shaft Sleeve-Top	门体轴套	PA66	2	
2	B0502207	SS Screw M5x12	M5x12不锈钢螺丝		12	
1	W0604032	Left-Top Hinge	左上铰链	SUS304	1	
序号	Material code	English Name	Chinese Name	MATERIAL	QUANTITY	Remark

92180102

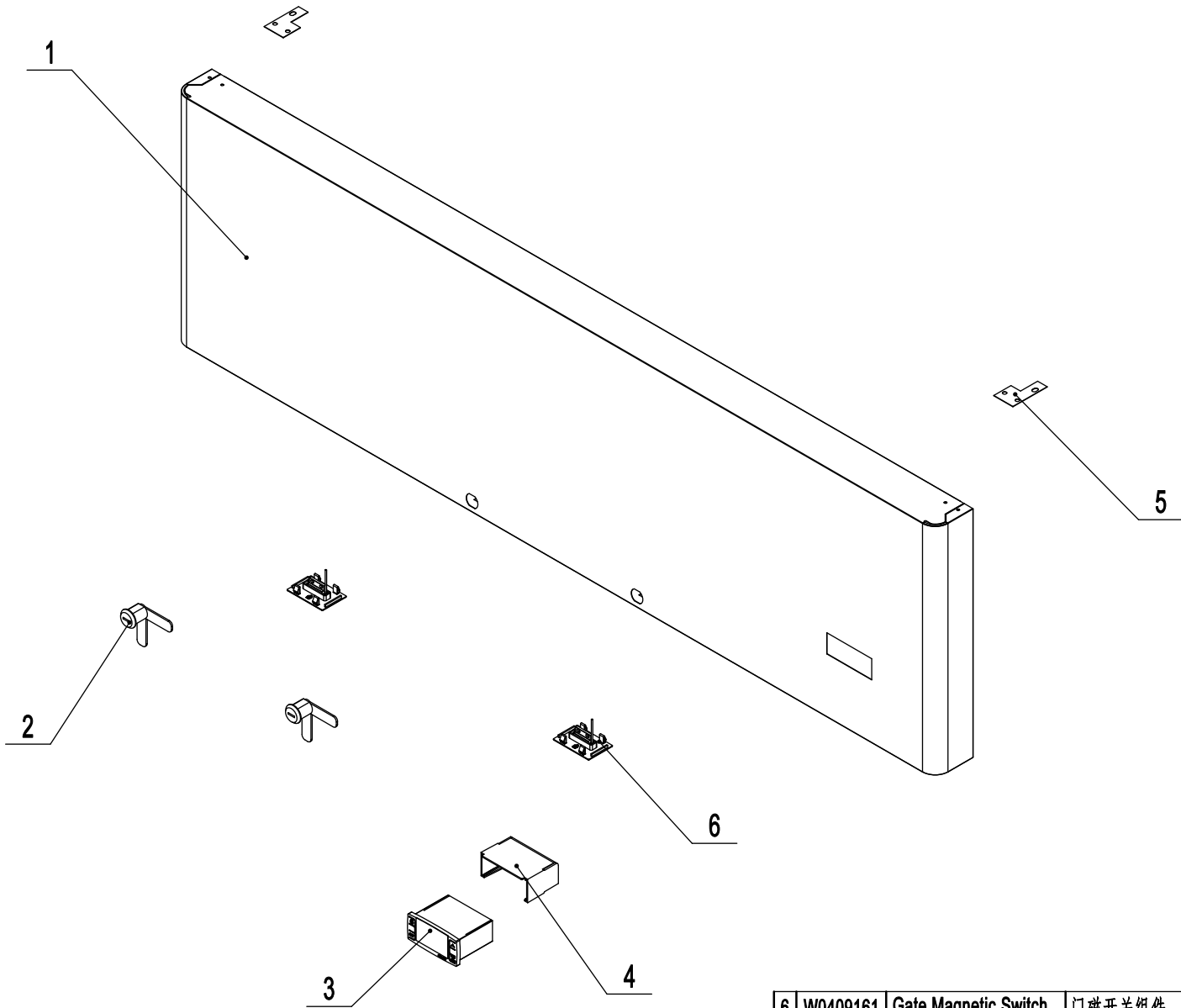

6	W0409161	Gate Magnetic Switch	门磁开关组件		2	
5	80021404	Fastener For Top Panel	上罩板加固件	SUS430	2	
4	W0302303	Controller Cover	防水后盖		1	
3	W0302185	Digital Controller	冷藏温控器(蓝色数码管)		1	220V
2	W0604007	Lock	冰箱锁		2	
1	92101411	Front Top Panel	前罩板		1	
序号	Material code	English Name	Chinese Name	MATERIAL	QUANTITY	Remark

92190103

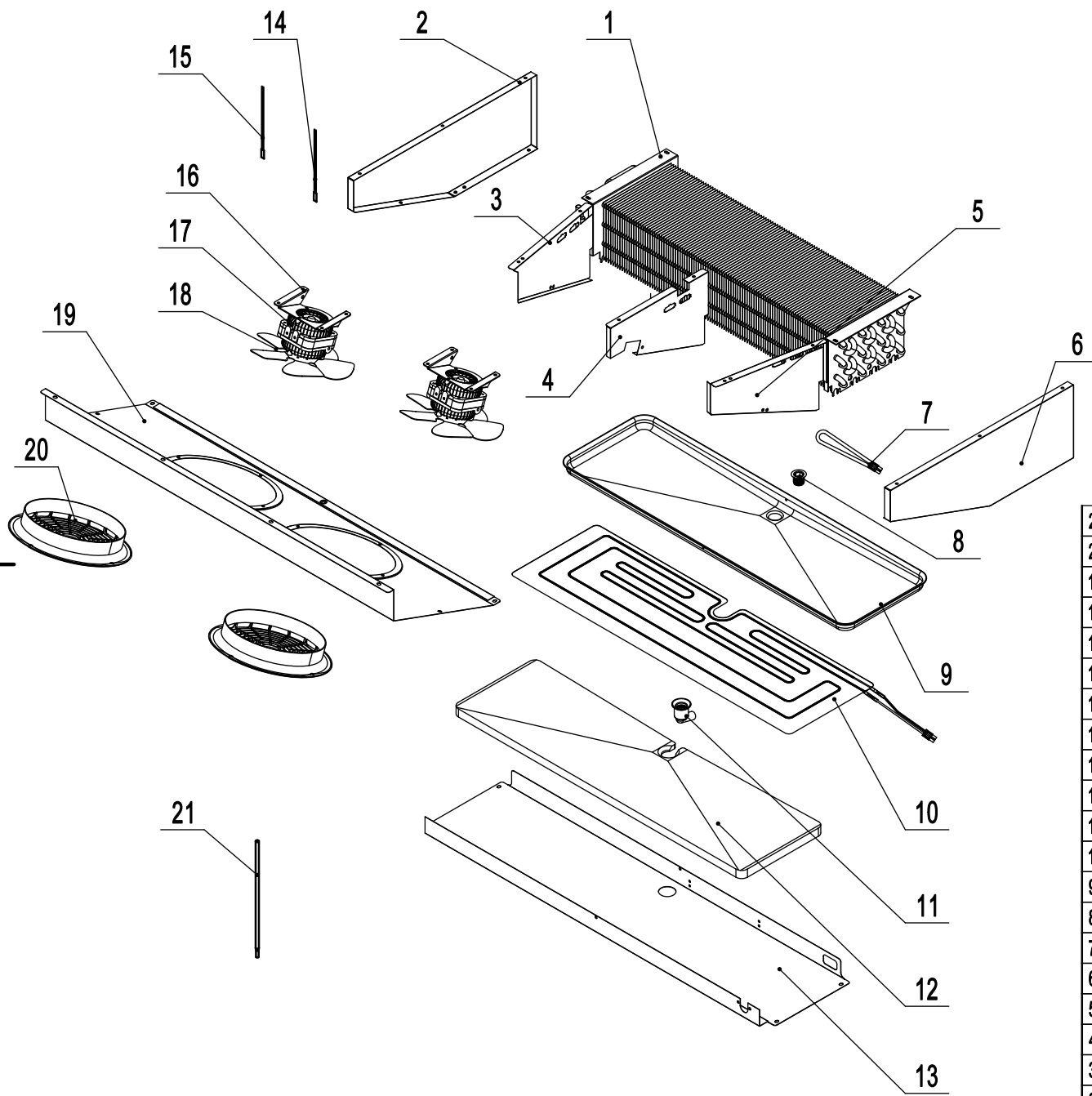

21	W0210707	Defrosting tube	化霜铜管	TP2-M	1	
20	W0409080	Evap Fan Motor Cover	蒸发风机罩	ABS	2	
19	92101225-430	Evap Front Cover	蒸发前盖板	SUS430	1	
18	W0301078	Evap Fan Blade	蒸发风叶	Ø172	2	
17	W0301913	Evap Fan Motor	蒸发风机		2	220V
16	80021501	Evap Fan Bracket	蒸发风机支架	SUS304	2	
15	W0302317	Evap Temp Probe	防水TPE除霜感温探头		1	
14	W0302316	Room Temp Probe	防水TPE冰箱感温探头		1	
13	92301204	Drain Pan Cover	蒸发后盖板	SUS430	1	
12	W0803012	Drain Pan Foam	接水盘泡沫	EPS	1	
11	W0409858	Drain Hose Connector A	排水管连接器A	PA66	1	
10	W0310121	Drain Pan Heater	接水盘加热带		1	220V
9	80022003	Drain Pan	铝制接水盘	AL	1	
8	W0409859	Drain Hose Connector B	排水管连接器B	PA66	1	
7	W0310067	Drain Hose Heater	排水管加热带		1	220V
6	92101221-430	Evap Right Cover	蒸发右挡板	SUS430	1	
5	92001224-430	Right Air Lane Cover	蒸发空气右挡板	SUS430	1	
4	92101224-430	Middle Air Lane Cover	蒸发空气中挡板	SUS430	1	
3	92001223-430	Left Air Lane Cover	蒸发空气左挡板	SUS430	1	
2	92101220-430	Evap Left Cover	蒸发左挡板	SUS430	1	
1	W0202135	Evaperator	蒸发器	AL TP2-M	1	
序号	Material code	English Name	Chinese Name	MATERIAL	QUANTITY	Remark

92190104

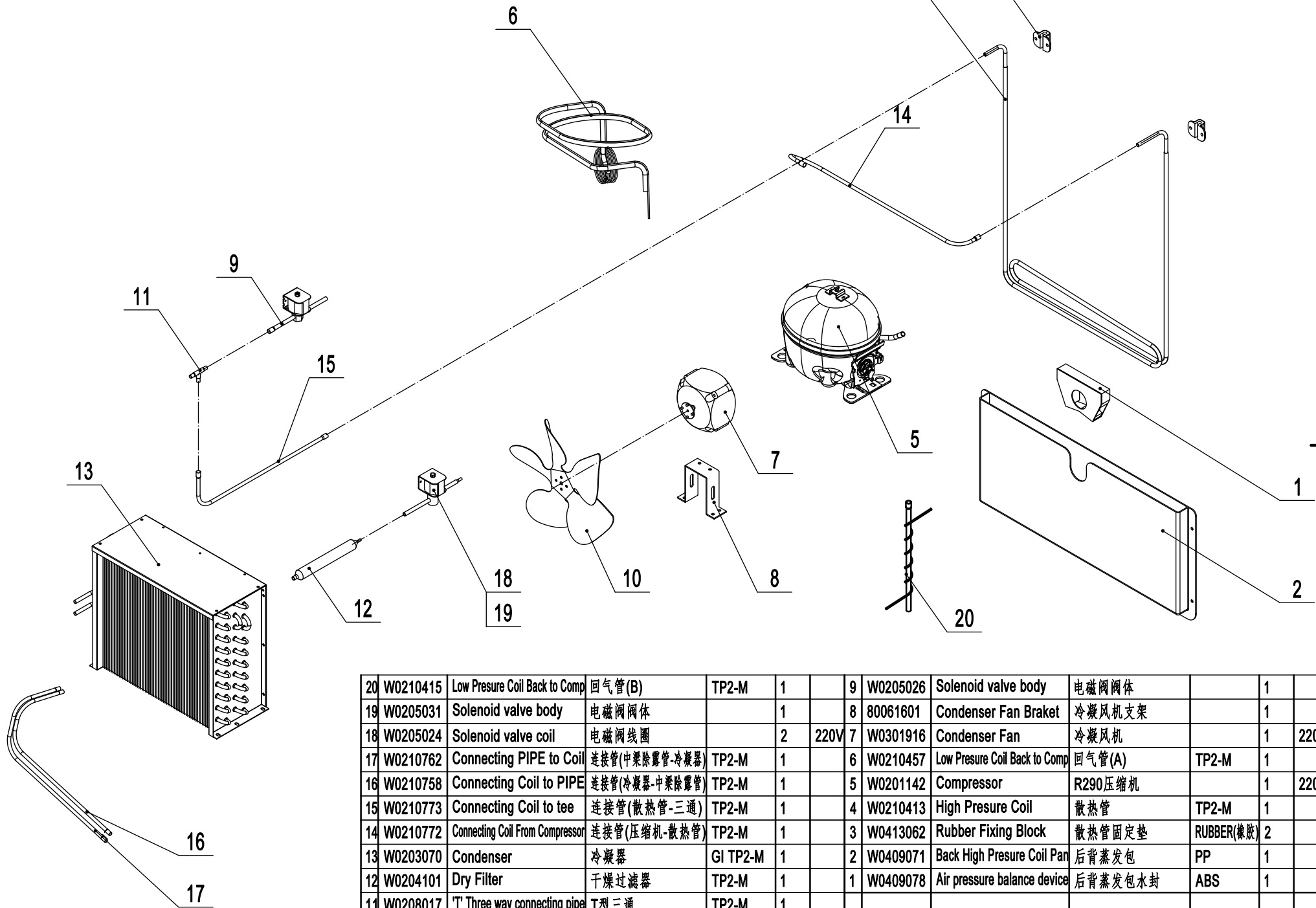

20	W0210415	Low Presure Coil Back to Comp	回气管(B)	TP2-M	1		9	W0205026	Solenoid valve body	电磁阀阀体		1	
19	W0205031	Solenoid valve body	电磁阀阀体		1		8	80061601	Condenser Fan Bracket	冷凝风机支架		1	
18	W0205024	Solenoid valve coil	电磁阀线圈		2	220V	7	W0301916	Condenser Fan	冷凝风机		1	220V
17	W0210762	Connecting PIPE to Coil	连接管(中架除露管-冷凝器)	TP2-M	1		6	W0210457	Low Presure Coil Back to Comp	回气管(A)	TP2-M	1	
16	W0210758	Connecting Coil to PIPE	连接管(冷凝器-中架除露管)	TP2-M	1		5	W0201142	Compressor	R290压缩机		1	220V
15	W0210773	Connecting Coil to tee	连接管(散热管-三通)	TP2-M	1		4	W0210413	High Presure Coil	散热管	TP2-M	1	
14	W0210772	Connecting Coil From Compressor	连接管(压缩机-散热管)	TP2-M	1		3	W0413062	Rubber Fixing Block	散热管固定垫	RUBBER(橡胶)	2	
13	W0203070	Condenser	冷凝器	GI TP2-M	1		2	W0409071	Back High Presure Coil Pan	后背蒸发包	PP	1	
12	W0204101	Dry Filter	干燥过滤器	TP2-M	1		1	W0409078	Air pressure balance device	后背蒸发包水封	ABS	1	
11	W0208017	'T' Three way connecting pipe	T型三通	TP2-M	1								
10	W0301061	Condenser Fan Blade	冷凝风叶	AL/Ø230	1		解号	Material code	English Name	Chinese Name	MATERIAL	QUANTITY	Remark

92190105

A

B

C

D

1

2

3

4

5

6

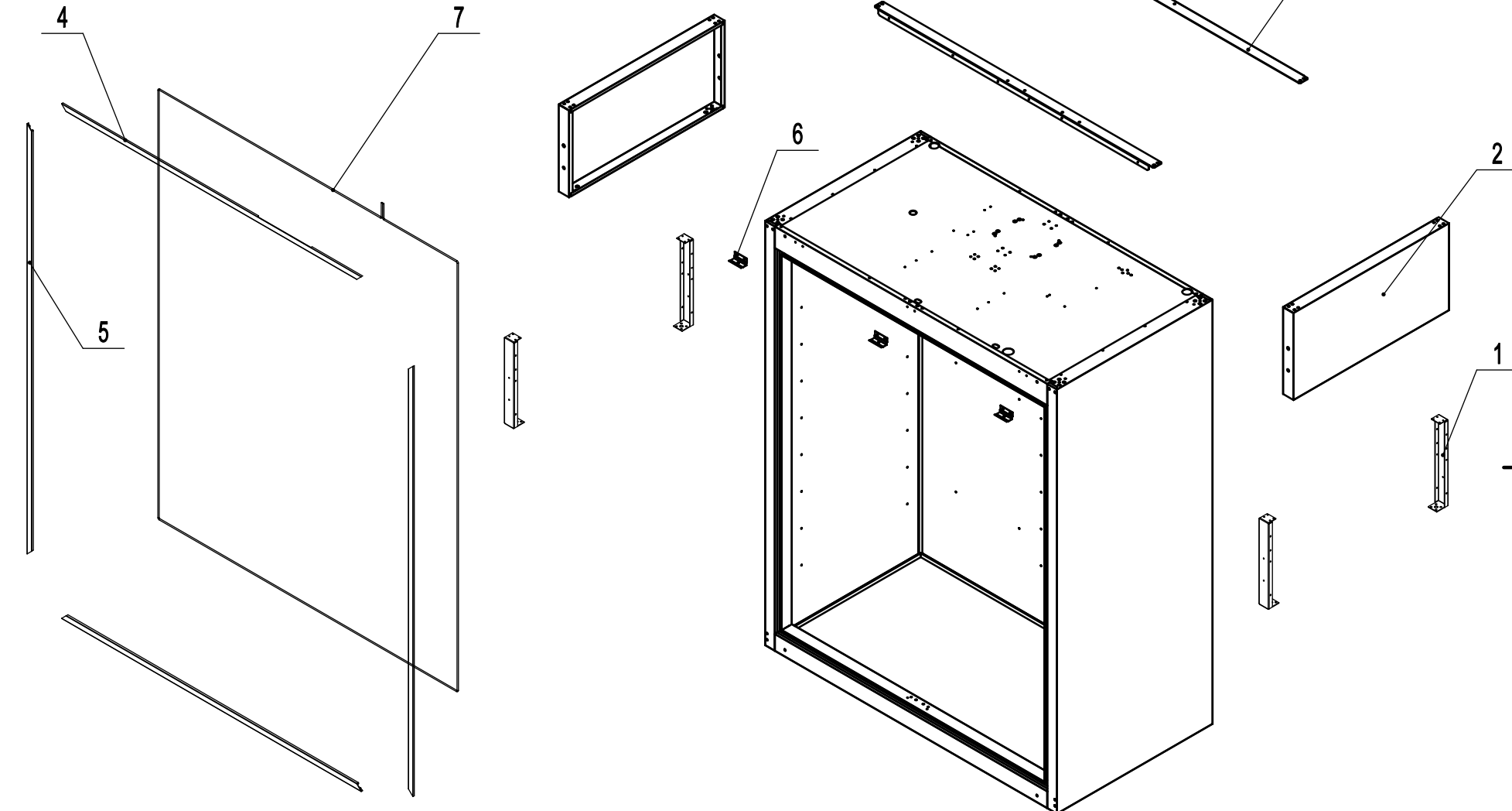

7	W0210768	Cabinet Heater Pipe	箱体除露管	TP2-M Ø5	1	
6	80021403	Fastener For Top Panel	上單板下加固件	SUS430	3	
5	W04101039	Left-Right Frame Cover	箱体左右接口盖	PVC-H	2	
4	W04101043	Top-Bottom Frame Cover	箱体上下接口盖	PVC-H	2	
3	11451801	Top Long Fixing Rack	箱体横向固定架	GI	2	
2	11451502	Side Panel Frame	箱体支撑架	GI	4	
1	92040906	Top Side Panel	箱体上侧板	SUS430	2	
序号	Material code	English Name	Chinese Name	MATERIAL	QUANTITY	Remark

90180106

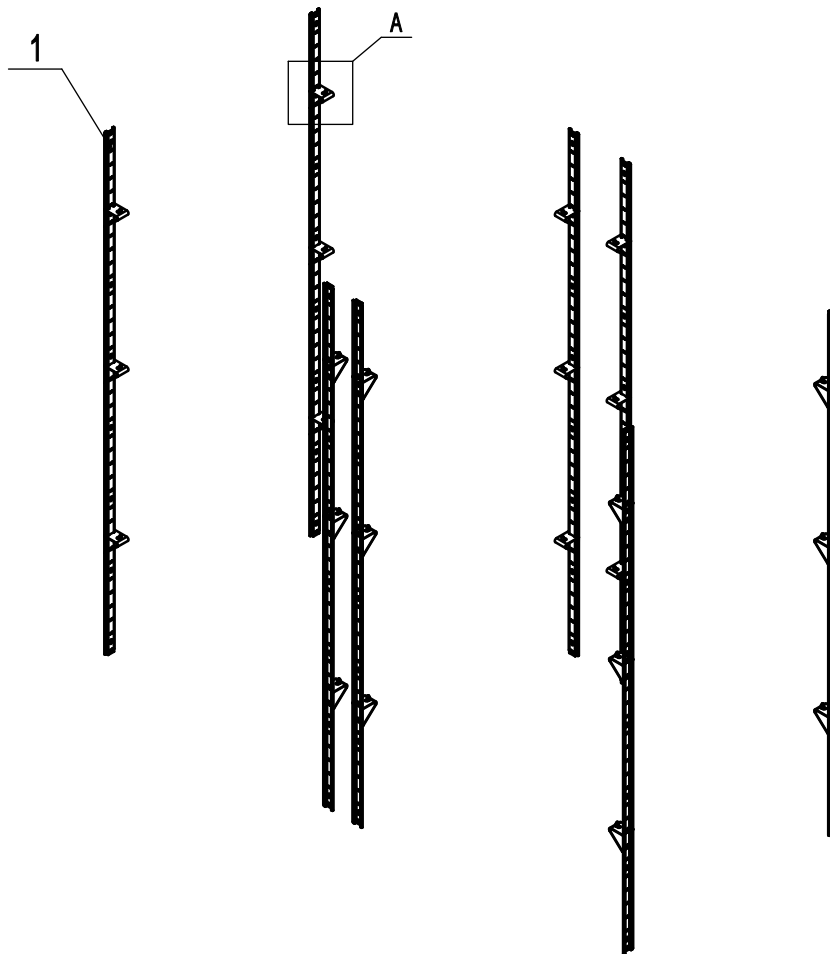
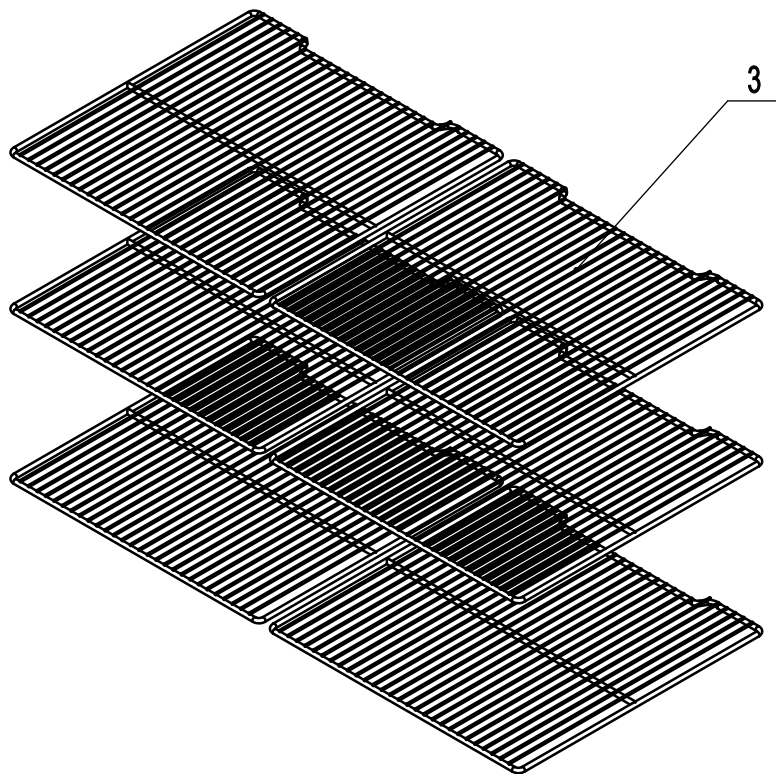
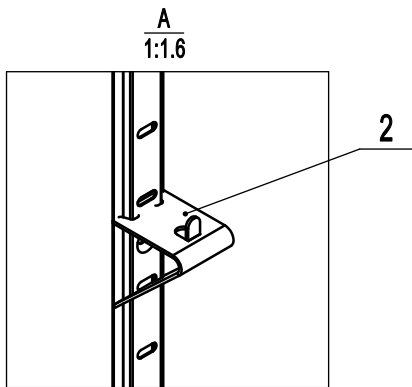

3	W0402674	Shelf	食品架		6	
2	66490313	Shelf Support Clip	食品架搁脚	SUS430	24	
1	80037410	Pilaster For Shelf	食品架隔条	SUS430	8	
序号	Material code	English Name	Chinese Name	MATERIAL	QUANTITY	Remark

92180107

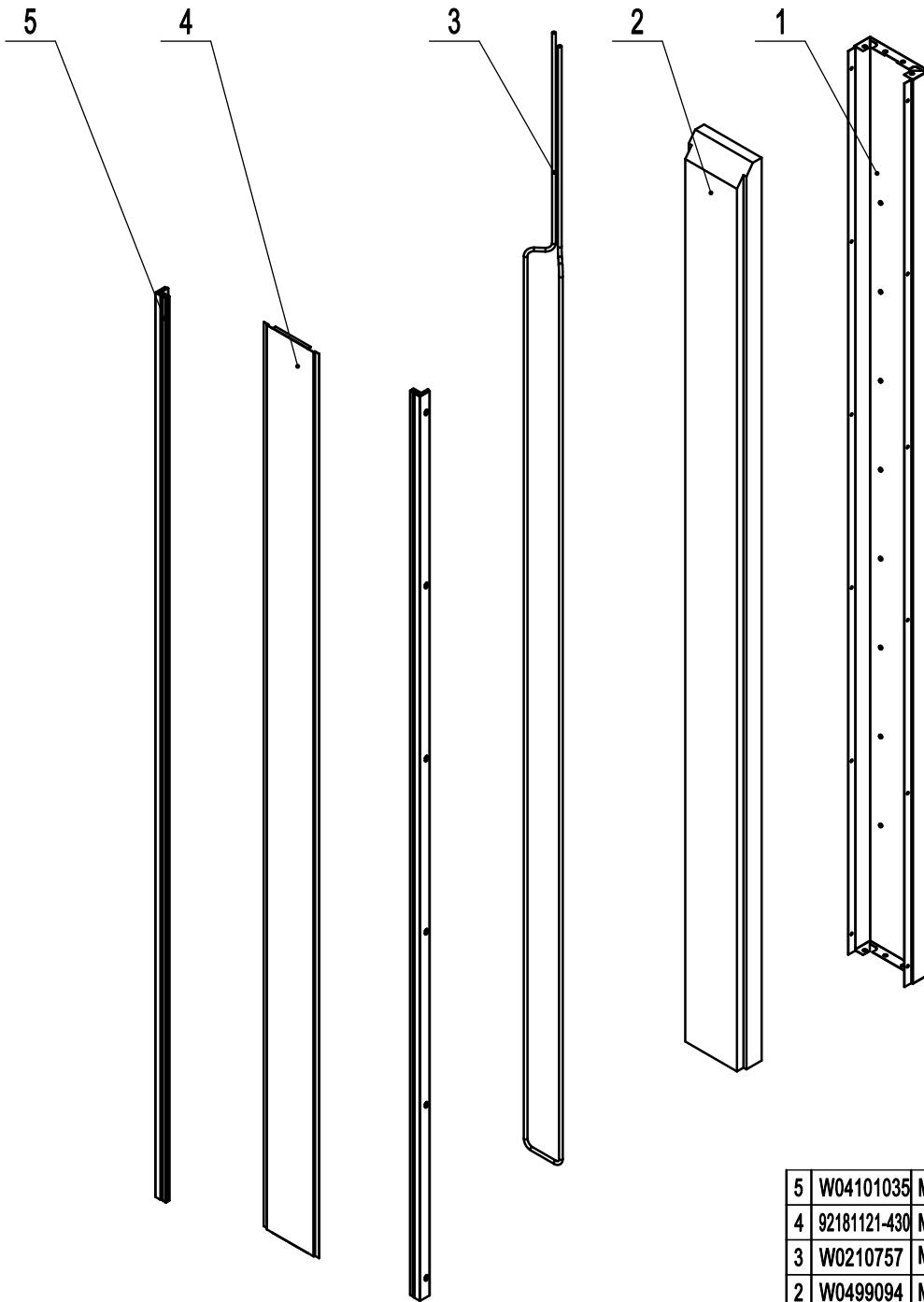

5	W04101035	Mullion Plastic Connector	竖中梁接口	PVC-H	2	
4	92181121-430	Mullion Front Cover	中梁前盖板	SUS430	1	
3	W0210757	Mullion Heater Pipe	中梁除露管		1	
2	W0499094	Mullion Foam	竖中梁泡沫	EPS	1	
1	92181120-430	Mullion Back Cover	中梁后盖板	SUS430	1	
序号	Material code	English Name	Chinese Name	MATERIAL	QUANTITY	Remark

80010455

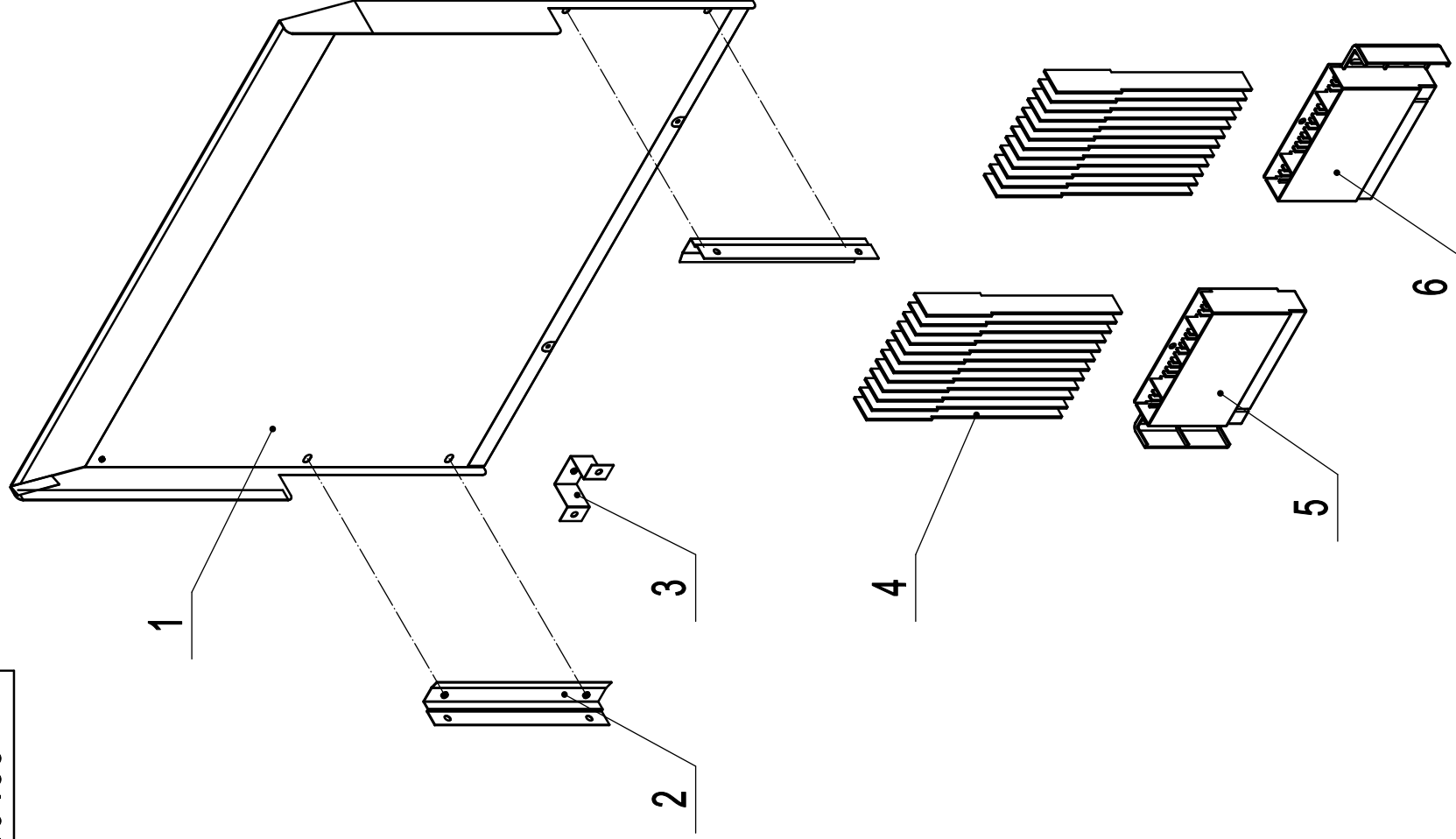

6	W0409086	Left bracket for Absorbent paper	左吸水纸支架	ABS	1	
5	W0409087	Right bracket for Absorbent paper	右吸水纸支架	ABS	1	
4	W0499920	Absorbent paper	吸水纸		24	
3	80011814	Middle fixing plate for Air deflector	蒸发包导风板中固定件		1	
2	80011813	Side fixing plate for Air deflector	蒸发包导风板侧固定件		2	
1	80010941	Air deflector	蒸发包导风板		1	
NO.	Material code	English Name	Chinese Name	Material	QUANTITY	Remark

1

2

3

4